

88980100 E

CONTROL DATA

CORPORATION

CONTROL DATA[®]
EL101-A COMPUTER INTERFACE UNIT
EL102-A COMPUTER INTERFACE
EXPANDER

GENERAL DESCRIPTION
OPERATION AND PROGRAMMING
INSTALLATION AND CHECKOUT
THEORY OF OPERATION
DIAGRAMS
MAINTENANCE
PARTS DATA
WIRE LIST

**HARDWARE REFERENCE/
CUSTOMER ENGINEERING MANUAL**

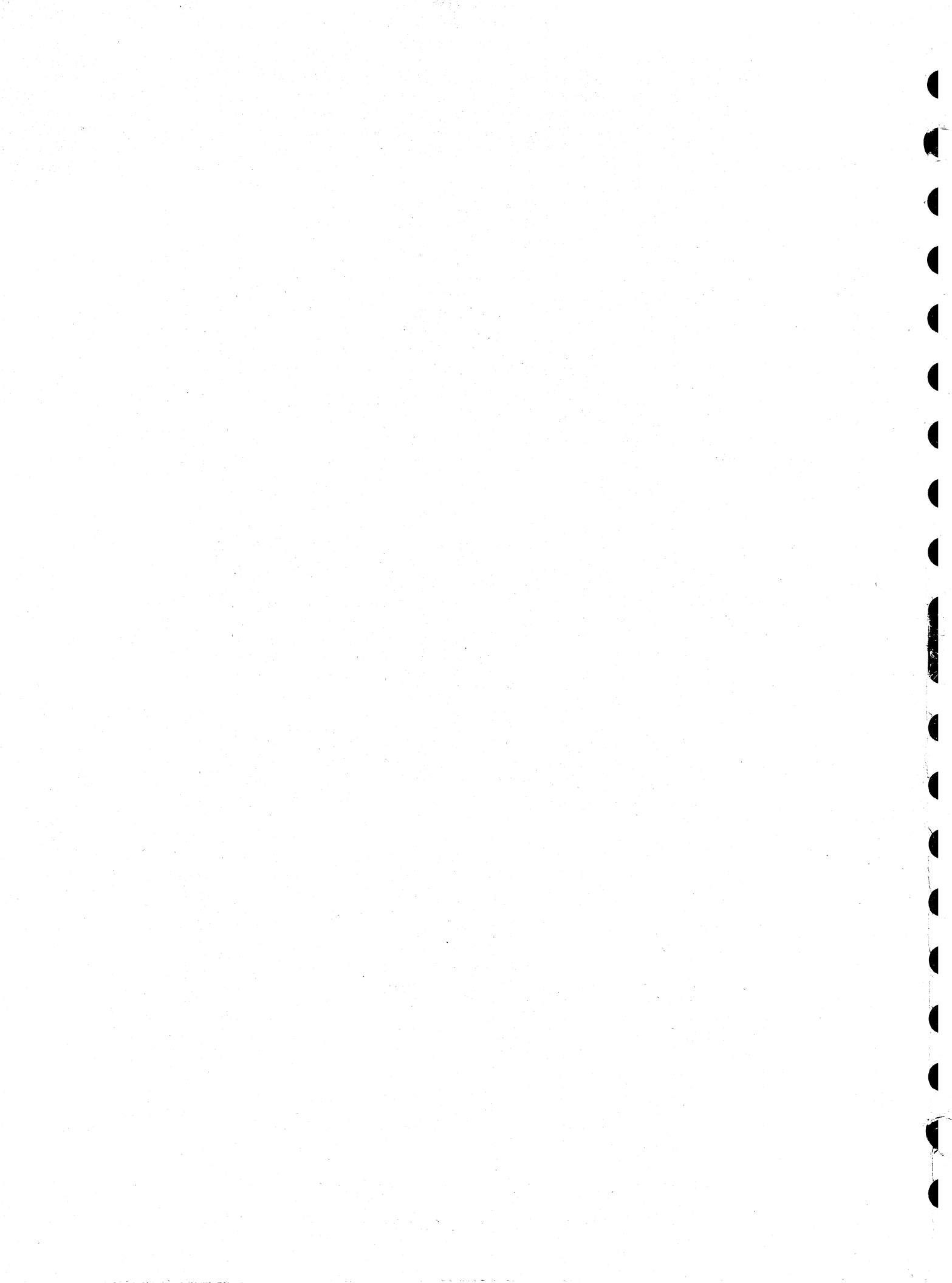



**CONTROL DATA[®]
EL101-A COMPUTER INTERFACE UNIT
EL102-A COMPUTER INTERFACE
EXPANDER**

GENERAL DESCRIPTION
OPERATION AND PROGRAMMING
INSTALLATION AND CHECKOUT
THEORY OF OPERATION
DIAGRAMS
MAINTENANCE
PARTS DATA
WIRE LIST

MANUAL TO EQUIPMENT LEVEL CORRELATION SHEET

This manual reflects the equipment configurations listed below.

EXPLANATION: Locate the equipment type and series number, as shown on the equipment FCO log, in the list below. Immediately to the right of the series number is an FCO number. If that number and all of the numbers underneath it match all of the numbers on the equipment FCO log, then this manual accurately reflects the equipment.

EQUIPMENT TYPE	SERIES	WITH FCOs	COMMENTS
EL101-A	01		
	02		
	03		
	04		
EL102-A	01		
	02		
	03		
	04		



LIST OF EFFECTIVE PAGES

New features, as well as changes, deletions, and additions to information in this manual, are indicated by bars in the margins or by a dot near the page number if the entire page is affected. A bar by the page number indicates pagination rather than content has changed.

PAGE	REV	PAGE	REV	PAGE	REV	PAGE	REV	PAGE	REV
Cover	--								
Title Page	--								
ii	E								
iii/iv	E								
v/vi	E								
vii/viii	D								
ix thru xii	D								
1.1 thru 1.6	A								
2.1 thru 2.6	A								
3.1 thru 3.7	A								
4.1 thru 4.7	A								
5.1 thru 5.3	A								
5.4	C								
5.5	D								
5.6 thru 5.8	A								
5.9 thru 5.26	B								
5.27 thru 5.35	A								
6.1 thru 6.6	A								
7.1/7.2	E								
7.3 thru 7.14	A								
7.15 thru 7.20	B								
7.21 thru 7.26	A								
7.27 thru 7.32	A								
8.1 thru 8.16	A								
8.17 thru 8.28	A								
8.29 thru 8.42	A								
Comment									
Sheet	E								
Cover	--								



TABLE OF CONTENTS

		Page
	PREFACE	iii
Section One GENERAL DESCRIPTION		
1.1	GENERAL	1.1
1.2	PHYSICAL DESCRIPTION	1.2
1.3	ELECTRICAL DESCRIPTION	1.2
1.4	PERFORMANCE/CHARACTERISTICS	1.3
1.4.1	Performance	1.3
1.4.2	Reliability	1.4
1.4.3	Maintenance	1.4
1.4.4	Human Engineering and Safety	1.5
1.4.5	Refurbishment	1.5
1.4.6	Materials, Processes and Parts	1.5
1.4.7	Electromagnetic Interference	1.5
1.4.8	Transportability/Packaging	1.6
1.5	EQUIPMENT CONFIGURATIONS	1.6
Section Two OPERATION AND PROGRAMMING		
2.1	CONTROLS AND OPERATION	2.1
2.2	JUMPERS AND EQUIPMENT CHANGES	2.1
2.2.1	Equipment Number Jumper	2.1
2.2.2	Program Protect Jumper	2.1
2.2.3	Module Select Jumper	2.1
2.2.4	Interrupt Jumpers	2.2
2.3	PROGRAMMING INFORMATION	2.2
2.3.1	General	2.2
2.3.2	Q-Register Description	2.2
2.3.3	A-Register Description	2.3
2.3.4	Interrupt/Flag Status Card	2.5
2.3.5	Rejects	2.5
2.3.6	Master Clear	2.6
2.3.7	Programming Considerations	2.6

TABLE OF CONTENTS (Continued)

	Page
Section Three	
INSTALLATION AND CHECKOUT	
3.1	INSTALLATION REQUIREMENTS 3.1
3.2	POWER REQUIREMENTS 3.1
3.3	CABLING AND CONNECTORS 3.1
3.4	INTERFACE CHARACTERISTICS 3.1
3.4.1	General 3.1
3.4.2	A/Q Interface 3.2
3.4.3	Data/Control Bus Interface 3.2
3.4.3.1	Signals 3.2
3.4.3.2	Signal Levels 3.2
3.4.3.3	Timing 3.4
3.4.3.4	Loading 3.5
3.4.3.5	Interface Circuits 3.5
3.4.4	CIU/CIE Bus Interface 3.5
3.4.5	External I/O Interface 3.6
3.5	COOLING REQUIREMENTS 3.7
3.6	ENVIRONMENTAL LIMITATIONS 3.7
3.7	PREPARATION FOR USE 3.7
Section Four	
THEORY OF OPERATION	
4.1	GENERAL 4.1
4.2	PRINCIPLE OF OPERATION 4.1
4.3	DETAILED THEORY OF OPERATION 4.2
4.3.1	Q Receivers and Decode (Card 2) 4.3
4.3.2	A-Line Transmitter/Receiver (Cards 3 and 4) 4.4
4.3.3	Address Control (Card 5) 4.4
4.3.4	Data Bus Driver/Receiver (Card 6) 4.4
4.3.5	Interrupt/Flag Status (Card 7) 4.4

TABLE OF CONTENTS (Continued)

		Page
	Section Five DIAGRAMS	
5.1	GENERAL	5.1
5.2	DIAGRAMS	5.1

	Section Six MAINTENANCE	
6.1	PREVENTIVE MAINTENANCE	6.1
6.2	CALIBRATION AND ALIGNMENT	6.1
6.3	TROUBLESHOOTING	6.1
6.3.1	Check Filters	6.2
6.3.2	Check Power Supplies	6.3
6.3.3	Run Diagnostic with Margins	6.3
6.4	MAINTENANCE AIDS	6.4

	Section Seven PARTS DATA	
7.1	PARTS DATA	7.1

	Section Eight WIRE LIST	
8.1	WIRE LIST.	8.1

LIST OF ILLUSTRATIONS

Figure		
4.1	Front Edge Connector Pin/Signal Orientation	4.8
5.1	CIU/CIE Block Diagram	5.2
5.2	CIU/CIE Power Wiring Diagram	5.3
5.3	CIU Cabling Diagram	5.4
5.4	CIU/CIE Bus Cabling	5.5

LIST OF ILLUSTRATIONS (Continued)

Figure		Page
5.5	Data/Control Bus Timing, Write Cycle	5.6
5.6	Data/Control Bus Timing, Read Cycle	5.7
5.7	Data/Control Bus Interface Circuits	5.8
5.8	CIU Control Logic Package	5.9
5.9	CIE Control Logic Package	5.27
6.1	Module Pin and Chip Location	6.5
6.2	Pin Configuration, Top View	6.6
7.1	Q-Line Receiver and Decode (1NBT)	7.3
7.2	A-Line Transmitter/Receiver (1NCT)	7.9
7.3	Address Control (1NDT)	7.15
7.4	Data Bus Driver/Receiver (1NET)	7.21
7.5	Interrupt and Flag Status (1NFT)	7.27
8.1	Backplane Wire List - CIU Module	8.3
8.2	Backplane Wire List - CIE Module	8.17
8.3	Chassis Wire List - CIU Module	8.29

LIST OF TABLES

Table		Page
2.1	CIU/CIE Module Station Addresses	2.4
3.1	CIU/CIE Data/Control Bus Signals	3.3
3.2	External I/O Interface	3.6
4.1	Functional Description of Cards	4.2
4.2	Glossary of Terms	4.6
6.1	Preventive Maintenance Index (PMI)	6.2
7.1	CIU/CIE Control Card List	7.1

Section One

GENERAL DESCRIPTION

1.1

GENERAL

The CONTROL DATA[®] Computer Interface Unit/Computer Interface Expander (CIU/CIE) is part of the 1500 product family. This product line provides a simplified interface to the CDC 1700/SC17 computers. The CIU/CIE will accept a wide range of computer input/output (I/O) devices. These include digital I/Os, analog I/Os, and real-time clocks as well as I/O controllers for typewriters, display panels, plotters, and other similar devices.

This manual describes the CIU/CIE interface control only and does not include descriptions of I/O devices that are inserted in the CIU/CIE. Refer to the Preface for manuals describing the separate I/O devices.

The computer interface unit (CIU) contains the circuitry that connects to the control computer. In addition, the CIU contains 16 station locations, all identically wired, in which input and output devices may be inserted. The address of each I/O device is determined by the station location which it occupies. Each station location consists of two card locations connected in parallel on the module backplane. Each location contains an integral I/O connector that provides 26 usable signal pins and two grounds for interfacing I/O devices to external equipment.

The system capability may be expanded through the use of computer interface expander (CIE) modules. Up to seven CIE modules may be connected to a CIU module thereby increasing the total number of station address locations to 128. Each CIE module, like the CIU module, contains 16 station locations for I/O devices. Also, the cards in the CIE module common drive circuitry are the same as those found in the CIU module.

One CIU/CIE system requires two successive equipment codes for proper operation. The even equipment code (N) is used for data transfer to/from the I/O

devices connected in the IOM. The next odd equipment code (N+1) is for function/status information to/from the I/O devices.

1.2

PHYSICAL DESCRIPTION

The CIU/CIE module is 8-3/4 inches high with front access plug-in circuit cards that are 7-3/4 inches by 9 inches in size. The CIU module control consists of printed circuit (PC) cards in positions 2 through 7. The CIE module control consists of PC cards in positions 5, 6 and 7. A connector panel assembly mounted on the back side of the CIU module provides connection to the 1700 A/Q lines, terminator power and eight interrupt lines. The CIE does not have a connector panel assembly.

Card position one is used for the interface between the CIU and CIE modules. A cable assembly (see Figure 5.4) connects to the card side of position one in the CIU and goes to the card side of the first CIE module. The first and second CIE modules are connected together by placing the cable assembly on the back panel side of position one. The cable assembly then alternates between the card side and back panel side to connect the remaining CIE modules together.

Power for the modules is provided by external power supplies mounted in the rack. A standard rack blower is required for cooling. See Section Three for a more detailed description.

External cabling can be plugged directly onto each I/O station address location from the outside world or via termination racks.

1.3

ELECTRICAL DESCRIPTION

The CIU/CIE power supplies require 117 vac, 50-400 Hz, single-phase primary power. Power conversion transformer rack option 10299-22 is required in the system when input power is 220/240 vac, 50 Hz. The internal power consump-

1.2

88980100 A

tion for a module is 70 watts (+5 vdc $\pm 5\%$, 14 amps) when fully loaded with 16 I/O devices. In addition, the CIU module requires -5 vdc $\pm 5\%$, 2 amps, 10 watts for the current mode transmitters and receivers. The logic is 7400 Series transistor-transistor logic (TTL) providing logic levels of:

- Logical zero (low) 0.4 vdc or less
- Logical one (high) +2.4 to +5.25 vdc

The interface logic levels between the module and I/O station devices are described in Paragraph 3.4.3.

1.4 PERFORMANCE/CHARACTERISTICS

1.4.1 PERFORMANCE

Requirements are:

- Programming capability Direct mode programming with station addresses (hexadecimal) of \$XXX0 through \$XXXF for the 16 station locations in a module.
- Data transfers Performed on base equipment number N, (0, 2, 4, 6, 8, A, C, or E)
- Function/status Performed on next successive equipment number (base number N + 1) (1, 3, 5, 7, 9, B, D, or F)
- Station flag line Each station location provides a separate flag line for interrupt generation.

- Interrupts
Eight interrupt lines are provided on the CIU module. Any one (or several) station flag line (in CIU or CIE module) may be jumpered to any one of the eight interrupt lines.
- Programming/systems considerations
Station address zero of each module is always used to read the status of the station flag lines.

I/O devices requiring status reads are not to be connected in station address location zero.

1.4.2 RELIABILITY

Requirements are:

- Mean time between failures (MTBF) - Estimated 30,000 hours for CIU module (design goal).
- Fail safe features - Power supplies contain overload and short circuit protection, and have over-voltage protection which crowbars the output if the output voltage rises between 1 and 2 volts above the nominal output voltage.

1.4.3 MAINTENANCE

Maintenance provisions are:

- Mean time to repair (MTTR) - Estimated 1.0 hour for CIU module (based upon board replacement).
- Preventive maintenance - See Section Six.

- Interchangeability - The A-Line transmitter/receiver cards in the CIU module are interchangeable (position 3 and 4). The address control card (position 5), the data bus driver/receiver card (position 6) and the interrupt/flag status card (position 7) are interchangeable between CIU and CIE modules. (Note that module select jumpers and interrupt jumpers would require changing as required for system application).
- Diagnostics available - Refer to SMM17 Diagnostic Test No. 90 in the SMM17 Reference Manual.
- Special test equipment required - None.
- Recommended test equipment - Digital Output Unit (DOU) and Digital Input Unit (DIU) for ease in testing the interface.

1.4.4 HUMAN ENGINEERING AND SAFETY

Not applicable.

1.4.5 REFURBISHMENT

Not applicable.

1.4.6 MATERIALS, PROCESSES AND PARTS

All connector and PC contacts are gold plated.

1.4.7 ELECTROMAGNETIC INTERFERENCE

Modules are designed in accordance with CDC-STD-1.30.020.

1.4.8

TRANSPORTABILITY/PACKAGING

Packaging for shipment shall be in accordance with the CDC General Quality Requirements Handbook and Supplier Packaging Specifications (refer to the Preface).

1.5

EQUIPMENT CONFIGURATION

Following are the major components of the CIU/CIE:

- Computer Interface Unit (CIU) - The CIU module consists of a PC backplane, connector panel assembly, six control cards, and will hold up to 16 I/O station address devices. Power is supplied by two power supplies, +5 vdc and -5 vdc, that are rack mounted. A/Q, power supply, and terminator power supply cables are supplied.
- Computer Interface Expander (CIE) - The CIE module consists of a PC backplane, three control cards, a module cable to connect to a CIU or a CIE module. Each CIE module will hold up to 16 I/O station address devices. Power is supplied by one +5 vdc power supply that is rack mounted.

Section Two

OPERATION AND PROGRAMMING

2.1 CONTROLS AND OPERATION

Not applicable.

2.2 JUMPERS AND EQUIPMENT CHANGES

2.2.1 EQUIPMENT NUMBER JUMPER

A jumper is provided on the Q-line receiver and decode card (position 2) to allow the CIU module to respond to equipment code numbers 0 through F. The CIU requires two successive numbers and the jumper provides this selection (e.g., 2 and 3, 8 and 9, C and D, etc.).

2.2.2 PROGRAM PROTECT JUMPER

A two position jumper is provided on the Q-line receive and decode card (position 2) for selecting the mode of program protect control for the CIU system. PROTECT ON allows only protected A/Q commands to be acknowledged. PROTECT OFF allows all A/Q commands to be acknowledged.

2.2.3 MODULE SELECT JUMPER

A jumper is provided on the address control card (position 5 of CIU and CIE modules) for selection of the module which is being addressed. MASTER position selected on the card in the master module allows addressing I/O devices in the CIU module. SLAVE 1, SLAVE 2, etc., selected on the card in a CIE module allows addressing of I/O devices in the appropriate CIE module.

2.2.4 INTERRUPT JUMPERS

Interrupt jumpers are provided on the interrupt/flag status card (position 7 in CIU and CIE modules) to allow any of the 16 flag lines in a module to be connected to any one of the eight interrupt lines. Any combination of flag lines to interrupt lines is allowed, using the nut and bolt jumpers provided on the card.

2.3 PROGRAMMING INFORMATION

2.3.1 GENERAL

The basic technique for generating I/O operations via the CIU/CIE is a direct connect mode where no continue feature is required. Station addresses are used to communicate with I/O unit devices. The CIU responds to two equipment code numbers N and N+1, where N is even (i.e., 0 and 1, 8 and 9, etc.). Data transfers are performed on equipment number N and function/status operations on equipment number N+1.

2.3.2 Q-REGISTER DESCRIPTION

The Q-register description is as follows:

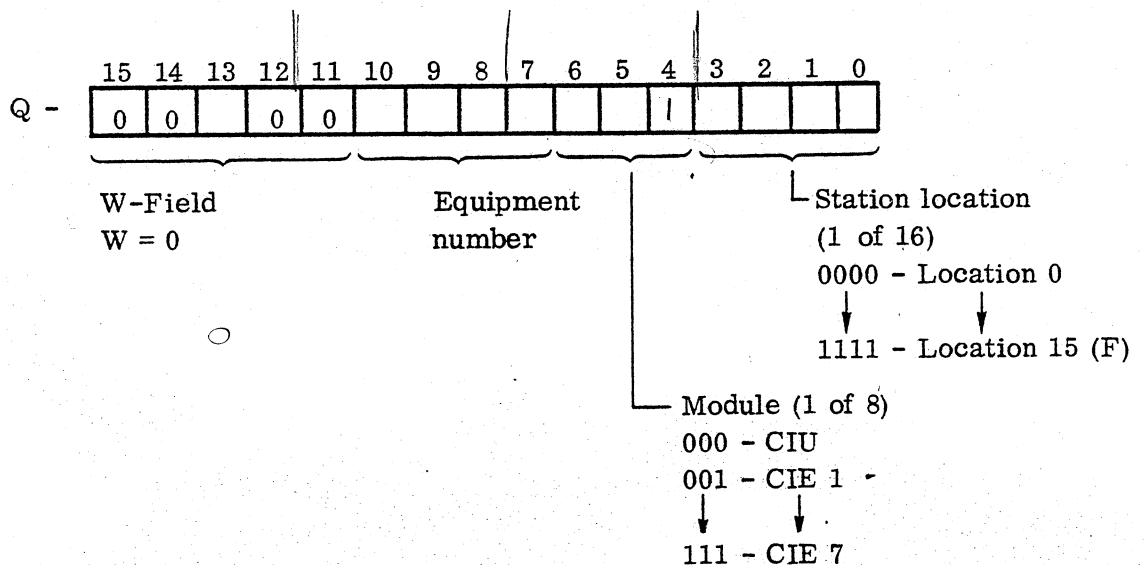

- 2
- Bits 0 through 3 - These bits contain the I/O station address. They are decoded for 1 of 16 station address locations in module.
 - Bits 4, 5 and 6 - These bits contain the module address. They are decoded for the CIU module or up to seven CIE modules in the system.
 - Bit 7 - This is the function/status bit contained in the equipment number.
When bit 7 = 0:
 - Write operation loads station device with data from the A register;
and
 - Read operation gates data from station device into the A register.
 When bit 7 = 1:
 - Write operation loads station device with function command contained in the A register; and
 - Read operation gates status from station device into the A register.
 - Bits 8, 9 and 10 - These bits contain the remaining bits of the equipment number of the CIU/CIE. The CIU responds to two equipment numbers N and N+1, where N is even. Data transfers are performed on equipment number N and function/status operations on equipment number N+1.
 - Bits 11 through 15 - These bits contain all zeros for the W-field. Table 2.1 provides the module station addresses for the possible equipment number connections.

2.3.3 A-REGISTER DESCRIPTION

The A register is used to transfer all information to/from the I/O unit devices. The type information contained in the A register is dependent upon bit 7 of Q as follows:

- Q bit 7 = 0 (data) - Bits 0 through 15 of A contain data to be transferred to/from the I/O station device during write/read operations.

Table 2.1. CIU/CIE Module Station Addresses

EQUIP - MENT CODE (ADDRESS)	STATION ADDRESS (HEXIDECIMAL)							OPERATION PERFORMED	
	CIU	CIE 1	CIE 2	CIE 3	CIE 4	CIE 5	CIE 6		CIE 7
0 and 1	000X	001X	002X	003X	004X	005X	006X	007X	Data Transfer
	008X	009X	00AX	00BX	00CX	00DX	00EX	00FX	Function/Status
2 and 3	010X	011X	012X	013X	014X	015X	016X	017X	Data Transfer
	018X	019X	01AX	01BX	01CX	01DX	01EX	01FX	Function/Status
4 and 5	020X	021X	022X	023X	024X	025X	026X	027X	Data Transfer
	028X	029X	02AX	02BX	02CX	02DX	02EX	02FX	Function/Status
6 and 7	030X	031X	032X	033X	034X	035X	036X	037X	Data Transfer
	038X	039X	03AX	03BX	03CX	03DX	03EX	03FX	Function/Status
8 and 9	040X	041X	042X	043X	044X	045X	046X	047X	Data Transfer
	048X	049X	04AX	04BX	04CX	04DX	04EX	04FX	Function/Status
A and B	050X	051X	052X	053X	054X	055X	056X	057X	Data Transfer
	058X	059X	05AX	05BX	05CX	05DX	05EX	05FX	Function/Status
C and D	060X	061X	062X	063X	064X	065X	066X	067X	Data Transfer
	068X	069X	06AX	06BX	06CX	06DX	06EX	06FX	Function/Status
E and F	070X	071X	072X	073X	074X	075X	076X	077X	Data Transfer
	078X	079X	07AX	07BX	07CX	07DX	07EX	07FX	Function/Status

NOTES:

1. X denotes \$0 - \$F and selects 1 of 16 unit locations in a module.
2. Station address \$YYY0 for each module is used to read the status of the station flag lines.

- Q bit 7 = 1 (function/status) - During write operations, bits 0 through 15 of A contain function bits for set-up of station device. Assignment of function bits is determined by station device requirements. During read operations, bits 0 through 15 of A contain status from station device.

2.3.4 INTERRUPT/FLAG STATUS CARD

The interrupt/flag status card responds to status reads (Q bit 7 = 1) on station address 0 for each module in the CIU/CIE system. Any I/O device inserted in station address 0 position shall not require (use) the status capability (Q bit 7 = 1).

When a status read is performed, the A register is loaded with the conditions of the 16 flag lines in the module. These flag lines can be jumpered to any one of the eight interrupt lines on the CIU/CIE system. The flags from the station devices are set and cleared at the device level, not in the CIU/CIE control. Bits 0 through 15 of A correspond to flag lines (station address locations) 0 through 15.

2.3.5 REJECTS

Internal rejects can result from the following:

- Equipment number not jumpered properly.
- A/Q command unprotected and CIU system jumpered for PROTECT ON.
- Module select jumper not positioned properly for specified address.
- I/O device not connected into station location being addressed.
- I/O device fails to respond with reply or external reject.
- I/O device is not designed for particular operation specified by I/O command.

External rejects signify the I/O device specified in the address is not ready. The control interface sections of the CIU/CIE modules do not generate external rejects.

2.3.6 MASTER CLEAR

A computer console master clear inhibits all data lines and sends a master clear to all I/O devices. A programmed master clear is not provided by the basic IOM interface. I/O devices that require a program clear are designed to respond to a program clear provided in a function operation for that device.

2.3.7 PROGRAMMING CONSIDERATIONS

The IOM requires two equipment numbers N and N+1, where N is even (i.e., 0 and 1, 8 and 9, etc.). Data transfers are performed on equipment number N and function/status operations on equipment number N+1.

Station address 0 for status reads is used by the CIU/CIE modules for providing status of the interrupt/flag lines. The I/O device connected in location 0 shall not require or use the status capability (Q bit 7 = 1).

Section Three
INSTALLATION AND CHECKOUT

3.1 INSTALLATION REQUIREMENTS

The CIU and CIE mount in a standard 19-inch wide equipment rack. Card access is from the front and cable connections are on the back. Rack mounted power supplies provide ± 5 vdc logic power. A standard rack blower is required for cooling. The module dimensions are:

- Height 8-3/4 inches
- Width 19 inches
- Depth 15 inches (including connector panel)
- Weight 25 pounds (estimated to include 16 I/O devices)

A maximum configured system requires one CIU module and seven CIE modules housed in two equipment racks.

3.2 POWER REQUIREMENTS

Logic power for the CIU/CIE modules is supplied from rack mounted +5 vdc and -5 vdc power supplies. Primary power of 115 ± 10 vac at 50-100 Hz, single phase, 0.12 KVA is required for the logic power supplies. Termination power for the current mode transmitters and receivers is supplied from the computer 40 vdc termination power supply. Figure 5.2 illustrates the power wiring for the CIU/CIE modules.

Note: Power conversion transformer rack option 10299-22 is required in the system when primary input power is 220/240 vac, 50 Hz.

3.3 CABLING AND CONNECTORS

Figure 5.3 specifies the cable and connector types to place the CIU/CIE in a system. Figure 5.4 illustrates the CIU/CIE bus cabling.

3.4 INTERFACE CHARACTERISTICS

3.4.1 GENERAL

The CIU contains the A/Q interface, the data/control bus interface, the CIU/CIE interface and the external I/O interface. All interfaces are identical in both the CIU and CIE modules, except the A/Q interface connects to the CIU module only.

3.4.2 A/Q INTERFACE

The CIU module provides party-line transmitters and receivers for the A/Q interface. Refer to the Input/Output Specification Manual for a description of the signals for this interface.

3.4.3 DATA/CONTROL BUS INTERFACE

3.4.3.1 Signals

The signals contained on the data/control bus are listed in Table 3.1. All devices designed for operating in a CIU/CIE station address location must be pin compatible with the data/control bus.

All station address locations are wired identically, with two card positions provided for each location. Two unique signals are provided for each location. They are:

- Station select line - Selects which station is to be addressed (to device).
- Data/interrupt flag line - Signifies station device has data ready or needs attention (from device).

Any device in a location may consist of one or two cards. Interconnection between two cards may be via any of the 26 connector lines not used on the I/O interface. Also, interconnection may be via a jumper cable between two connectors located on the front of the cards. A complex device interface may occupy more than one station address location providing all basic interface rules are met.

3.4.3.2 Signal Levels

Polarity of the signal lines are:

- False or non-active signal = +2.4 to 5.25 vdc
- True or active signal = 0.4 vdc or less

Table 3.1. CIU/CIE Data/Control Bus Signals

PIN NO.	SIGNAL	DESCRIPTION
A1	V + 5	+5 vdc power
B1	GND 1	Ground line
NOTE: The following two signals are unique to each unit location (wire-wrapped):		
A2	SS00F-SS15F	Station select signal to each appropriate station address location.
B2	FL00F-FL15F	Data/interrupt flag signal from each appropriate station address location.
NOTE: The following signals are common to each station address location (PC clad):		
A3	DB 00F	} Bi-directional data word Bits 00 - 15
B3	DB 01F	
A4	DB 02F	
B4	DB 03F	
A5	DB 04F	
B5	DB 05F	
A6	DB 06F	
B6	DB 07F	
A7	DB 08F	
B7	DB 09F	
A8	DB 10F	
B8	DB 11F	
A9	DB 12F	
B9	DB 13F	
A10	DB 14F	
B10	DB 15F	
A11	READF	Read line to station devices
B11	WRITF	Write line to station devices
A12	FUSTF	Function/status line to station device Q7=0: Data on word bus Q7=1: Function/status performed by info on word bus
B12	RPLYF	Reply signal from station device
A13	RJCTF	Reject signal from station device

Table 3.1. CIU/CIE Data/Control Bus Signals (Continued)

PIN NO.	SIGNAL	DESCRIPTION
B13	MCLRF	Master clear - 1700 console Master clear to station device
A14	ISY1F	Internal sync 1 line between station devices
B14	ISY2F	Internal sync 2 line between station devices
A15	CHINF	Character input from station devices
B15	STAFL	Stall line between station devices

NOTES:

1. Signals on pins A2 through A15 and B2 through B15 are on the CIU/CIE data/control bus in inverted (false) form.
2. A logical 1 (+2.4 to 5.25 vdc) represents a false (non-active) signal on the bus.
3. A logical 0 (0.4 vdc or less) represents a true (active) signal on the bus.

During the master clear pulse, the data lines will be false (not activated) such that registers may be cleared via a console master clear pulse. It should be noted that the CIU/CIE modules do not have a programmable master clear.

3.4.3.3 Timing

The control signals at the station device level are an extension of the A/Q timing of the 1700 or SC17. Figure 5.5 illustrates a write cycle. Data is placed on the bus and the station select line is sent to the decoded station device when a computer write is received. The bus timing is initiated by the bus write line and is delayed to allow all data and address lines to settle.

Figure 5.6 illustrates a read cycle. The station select line is sent to the decoded station device and the A-line transmitters are enabled when a computer read is received. The bus timing is initiated by the bus read line and is delayed to allow the address lines to settle. The unit device reply is delayed by the CIU control section to allow the data lines to settle before the reply is sent to the computer.

The I/O device sends a reply or reject signal after receipt of either a bus write or a bus read signal. The I/O devices are designed with an interlock circuit

to prevent sending both a reply and a reject during the same input or output operation.

3.4.3.4 Loading

Each I/O device is restricted to the following loading on the bus interface:

- Receivers – No more than three low power receivers (type 74L04) are to be tied to one line. This allows 0.6 milliamperes maximum per line.
- Transmitters – Each device shall drive the bus with a gated open collector NAND gate capable of sinking 16 milliamperes of bus current. When only one transmitter in a device is tied to a bus line, a type 7403 NAND gate shall be used. When two or more transmitters in a device are connected to the same bus line, type 7426 NAND gates shall be used.

3.4.3.5 Interface Circuits

Figure 5.7 shows the circuits used to drive the CIU/CIE data/control bus. All devices designed for operation with the CIU/CIE must use these circuits for transmitting/receiving data and control. A device is allowed to place data or status on the bus only during the time it is selected. All transmitters must be inhibited when the device is not selected.

3.4.4 CIU/CIE BUS INTERFACE

The interface between the CIU and a CIE module, or between CIE modules, is via twisted pair cables. Signal lines are:

- Sixteen bi-directional data lines
- Seven module select lines
- Four Q-address lines, bits Q00 through Q03, to be decoded for the 16 station select lines in each module.
- Read line
- Write line
- Reply line

- Character input line
- Two sync lines
- Reject line
- Console master clear line
- Function/status line
- Eight common interrupt lines
- Stall signal line

The interface between the CIU and CIE modules is connected via a cable assembly plugged into card position one. Cable assembly Part No. 39905500 is used when the modules are adjacent to one another. Cable assembly Part No. 39905501 is used when a booster blower is located between two of the modules.

3.4.5 EXTERNAL I/O INTERFACE

The signals and pins available on the external I/O interface are listed in Table 3.2. Each I/O station address location consists of two card positions with 26 interface pins bussed together. The I/O cable connects to the appropriate connector (J01-J16) on the rear of the backplane. Logic power, other than +5 vdc (if required for analog circuits), may be connected to the special power pins (A16, B16, A17, B17) adjacent to the corresponding I/O connector (see Figure 5.3).

Table 3.2. External I/O Interface

PIN NO.	SIGNAL	DESCRIPTION
A16, B16, A17, and B17	Special power	Pins adjacent to each I/O connector for special power input.
A18 thru A31	Unassigned	I/O signals assigned by station device
B18	GND 1	Ground line
B19 thru B30	Unassigned	I/O signals assigned by station device
B31	GND 2	Ground line

3.5 COOLING REQUIREMENTS

Air flow of 350 cfm is required across each PC card in system applications to assure adequate component lifetime. Air flow of 350 cfm will be realized in a rack using a standard rack blower assembly, Part No. 39514900, with modules stacked three high. More than three modules require a second blower assembly placed between the third and fourth modules in the rack. Plenum inlet air temperature may be from 40°F to 120°F. The average power dissipation of a CIU/CIE module with 16 I/O devices is estimated at 70 watts.

3.6 ENVIRONMENTAL LIMITATIONS

- Non operating:

Altitude	-1,000 feet to +15,000 feet
Temperature	-30° F to +150° F
Relative Humidity	5% to 95% (without condensation)

- Operating:

Altitude	-1,000 feet to +6,000 feet
Temperature	40° F to 120° F
Relative Humidity	10% to 90% (without condensation)
Warm-up Time	15 minutes

3.7 PREPARATION FOR USE

Verify power supplies are properly connected to module. Verify control cards are installed in correct positions. Verify proper equipment number. Verify program protect and module select jumpers are correctly installed for system configuration.

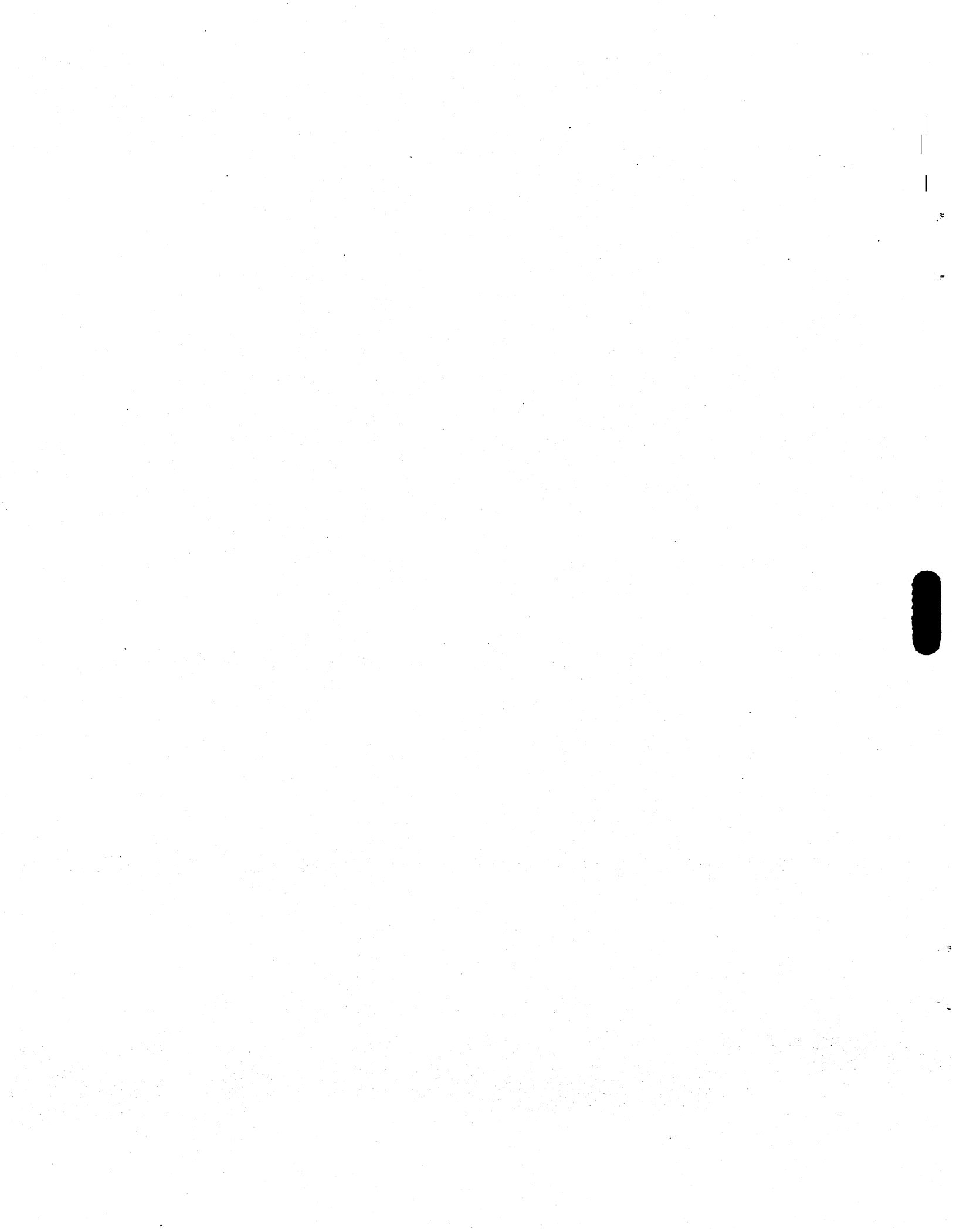

Section Four

THEORY OF OPERATION

4.1 GENERAL

The CIU provides a simplified interface between the 1700 Series computers and a wide range of I/O devices. These include digital inputs and outputs, analog inputs and outputs, real-time clocks, etc. The I/O control provides a 7400 Series transistor-transistor logic (TTL) compatible A/Q interface. The Q = address is pre-decoded into one address per each I/O device connected in the CIU module. The reply/reject control is performed by each I/O device in the CIU. The CIU module contains 16 station address locations where I/O devices can be connected. The base module capability may be expanded through the use of CIE modules each of which also contain 16 station address locations. Up to seven of these CIE modules may be used bringing the total number of available I/O station address locations up to 128.

4.2 PRINCIPLE OF OPERATION

A block diagram of the CIU module is shown in Figure 5.1. Also shown in the diagram are a digital input and a digital output device installed in two of the 16 station address locations.

The CIU can be jumpered to acknowledge all A/Q commands, or only protected A/Q commands. When jumpered for PROTECT ON, unprotected commands will not be acknowledged and an internal reject will occur. The CIU requires two successive equipment numbers, N and N+1 where N is even.

Data transfers are performed on equipment number N and function/status' operations are performed on equipment number N+1. The equipment number is selected by jumper arrangement on Q-line receiver/decode card (position 2).

When the selected equipment number is on the Q-lines, the CIU module becomes connected. The station address specified in Q-bits 0 through 6 is decoded as follows:

- Q-bits 0 through 3 are sent to each module in the system and decoded for the station address device location in the module.

- Q-bits 4 through 6 are decoded for one of eight modules (CIU or one of seven CIEs). The seven CIE module lines are sent to each CIE module on the CIU/CIE interface bus.

A computer write operation gates information from the A-lines to the addressed device. A computer read operation gates information from the addressed device to the computer A-lines. The A-lines are gated-on in only the one module being addressed. All other modules are in the off state. The reply/reject control is performed by each addressed device in the system. The reply/reject signals are delayed in the CIU module to allow line settling for the data.

Figures 5.5 and 5.6 illustrate the timing between the computer, the CIU module and the I/O device in a CIU module. Table 4.2 at the end of this section defines the signal mnemonics and terms.

4.3 DETAILED THEORY OF OPERATION

A brief functional description of each card in the CIU interface control is described in Table 4.1. Subsequent paragraphs provide a detailed description of each card type. Figure 5.8 is the logic package for the CIU interface control and Figure 5.9 is the logic package for the CIE control.

Table 4.1. Functional Description of Cards

CARD POSITION(S)	CARD TITLE	FUNCTIONAL DESCRIPTION
2	Q-Line Receiver and Decode (1NBT)	16 receivers for Q-lines and control signals. Decodes equipment number, module selected, and gating for read/write operations.
3, 4	A-Line Transmitters/Receivers (1NCT)	Eight transmitter/receiver circuits that connect A-lines to master module, reply/reject transmitters and four interrupt transmitters per card.

Table 4.1. Functional Description of Cards (Continued)

CARD POSITION(S)	CARD TITLE	FUNCTIONAL DESCRIPTION
5	Address Control (1NDT)	Decodes 1 of 16 station locations for each module. Contains read/write and reply/reject gating circuitry to bus.
6	Data Bus Driver/Receiver (1NET)	Contains 16 driver/receiver circuits that connect the common bus to all I/O devices in a module.
7	Interrupt/Flag Status (1NFT)	Provides status for flags from 16 station locations. Flag line can be jumpered for interrupt to computer.

4.3.1 Q RECEIVERS AND DECODE (CARD 2)

This card provides the jumpers for selecting the equipment number and program protect mode for the system. It contains receivers for Q-bits 0 through 10, and control signals read, write, program protect, W=0, and master clear.

The card connects to A/Q when Q-bits 8 through 10 correspond to the selected equipment number. Q-bits 4 through 6 are decoded for the CIU or one of seven CIE modules. When a read or write signal is received from the computer, the following signals are gated to the CIU and CIE modules:

- Connect read or write
- Module read or write
- Module select signals (1 of 8)
- Q-bits 0 through 3 (for station location decode)
- Q-bit 7 function/status

The console master clear is not gated, but connects directly to the CIU/CIE modules.

4.3.2 A-LINE TRANSMITTER/RECEIVER (CARDS 3 AND 4)

This card contains eight current mode transmitter/receiver circuits that connect the computer A-lines to the CIU module. A module connect read (MCRDF) gates the transmitters to the computer. A module connect write (MCWTF) gates information from the receivers to the CIU/CIE modules. The circuits are held in the off state until a read or write is received.

Four transmitters are provided on the card for generating interrupts to the computer. The transmitter outputs connect to the interrupt connectors on the master module connector panel.

Two transmitter delay circuits are provided for sending reply, reject and character input signals to the computer. The delay allows the data lines to settle before responding to the I/O operation.

4.3.3 ADDRESS CONTROL (CARD 5)

This card provides the control for gating data and control signals to/from the data bus. A jumper is provided for selecting the CIU module and CIE modules in a system. The data and control signals are gated to/from the data bus during a read or write cycle when a signal on a module select line corresponds to the position of the jumper. The lower four bits (MQ00F - MQ03F) of the address are decoded to select 1 of 16 station locations (SS00F - SS15F) in the module. The connect write (CNWTF) gating term holds data on the bus for a minimum of 100 nanoseconds after the computer write term (WRITF) is disabled.

4.3.4 DATA BUS DRIVER/RECEIVER (CARD 6)

This card provides the gating of data to/from I/O devices in a CIU/CIE module. The signal connect write (CNWTF) gates data to the station locations during a computer write operation. The signal connect read (CNRDF) gates data from a station location to the computer on a read operation. The data bus is in the inactive state when no operations are being performed.

4.3.5 INTERRUPT/FLAG STATUS (CARD 7)

This card provides status of the flag signals (FL00F - FL15F) from each station location in a module. The status of these flag lines is gated to the computer when

the status bit (Q bit 7) in the address is a logical 1 and a read is performed on station address 0 of the selected module. An 8 by 16 matrix is provided on the board to allow any combination of flag lines to be jumpered (by nut and bolt) to any one of eight interrupt lines.

A front edge connector on the board provides the capability to connect external signals (such as a digital output unit) as inputs to the flag line. This provides a maintenance aid in exercising the flag and interrupt lines. The connector input is pin and bit compatible to the front edge connector that may be located on a digital output unit (see Figure 4.1).

Table 4.2. Glossary of Terms

TERM	DEFINITION
\$A00 - \$A15	A-line data bits to/from CPU
\$Q00 - \$Q10	Q-line address bits from CPU
\$READ	Read signal from CPU
\$WRITE	Write signal from CPU
\$WEQ0	W-field equals 0 from CPU
\$PPRO	Program protect signal from CPU
\$MCLF	Console master clear false from CPU
\$REPLY	Reply to CPU
\$REJECT	Reject to CPU
\$CHIN	Character input to CPU
\$INT1 - \$INT8	Interrupt lines 1 through 8 to CPU
MQ00F - MQ03F	Module Q-bits 00 through 03 false
MASTF	Master (CIU) module false
SLV1F - SLV7F	Slave 1 (CIE 1) - slave 7 (CIE 7) false
STALF	Stall signal from stall alarm unit

Table 4.2. Glossary of Terms (Continued)

TERM	DEFINITION
MRDF	Module read false
MWTF	Module write false
MFSTF	Module function/status false
MCRDF	Module connect read false
MCWTF	Module connect write false
MMCLF	Module master clear false
MCINF	Module character input false
MA00F - MA15F	Module data lines 00 through 15 false
INT1F - INT8F	Interrupt lines 1 through 8 false
MRPYF	Module reply false
MRJTF	Module reject false
SS00F - SS15F	Station select lines 00=15 false
CNRDF	Connect read false
CNWTF	Connect write false
FUSTF	Function/status false (bus)
MCLRF	Master clear false (bus)
READF	Read false (bus)
WRITF	Write false (bus)
RPLYF	Reply false (bus)
RJCTF	Reject false (bus)
CHINF	Character input false (bus)
ISY1F	Internal sync 1 false (bus)
ISY2F	Internal sync 2 false (bus)
DB00F - DB15F	Data bits 00 through 15 false (bus)
FL00F - FL15F	Flag lines 00 through 15 false

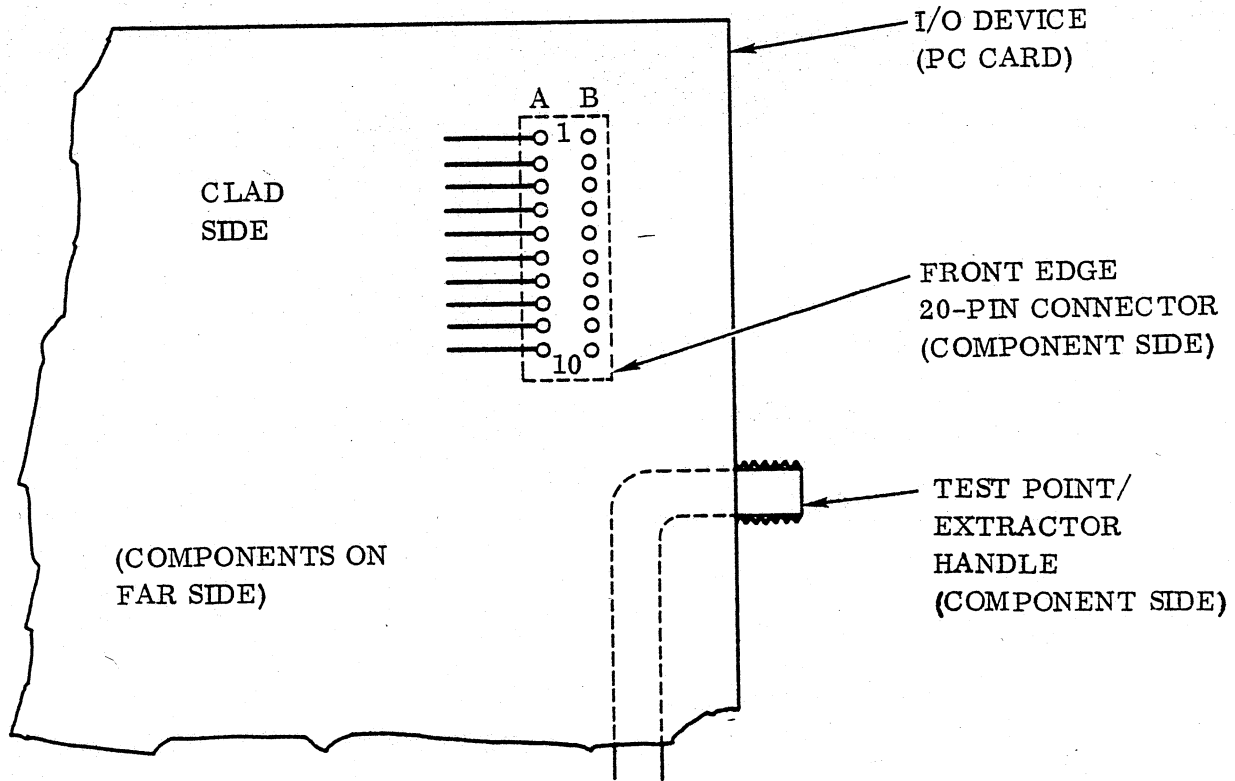

PIN NO.	REFERENCE DIGITAL OUT (1NLT)	REFERENCE * DIGITAL IN (1NKT)	INTERRUPT FLAG STATUS (1NFT)
A1	-	-	-
A2	BIT 0 OUT	BIT 0 IN	FLAG 0 IN
A3	BIT 1 OUT	BIT 1 IN	FLAG 1 IN
A4	BIT 2 OUT	BIT 2 IN	FLAG 2 IN
A5	BIT 3 OUT	BIT 3 IN	FLAG 3 IN
A6	BIT 4 OUT	BIT 4 IN	FLAG 4 IN
A7	BIT 5 OUT	BIT 5 IN	FLAG 5 IN
A8	BIT 6 OUT	BIT 6 IN	FLAG 6 IN
A9	BIT 7 OUT	BIT 7 IN	FLAG 7 IN
A10	BIT 15 OUT	BIT 15 IN	FLAG 15 IN
B1	REQUEST IN	COMPLETE OUT	-
B2	READY OUT	REQUEST IN	-
B3	RESET IN	RESET IN	-
B4	BIT 8 OUT	BIT 8 IN	FLAG 8 IN
B5	BIT 9 OUT	BIT 9 IN	FLAG 9 IN
B6	BIT 10 OUT	BIT 10 IN	FLAG 10 IN
B7	BIT 11 OUT	BIT 11 IN	FLAG 11 IN
B8	BIT 12 OUT	BIT 12 IN	FLAG 12 IN
B9	BIT 13 OUT	BIT 13 IN	FLAG 13 IN
B10	BIT 14 OUT	BIT 14 IN	FLAG 14 IN

*AFTER INPUT SIGNAL CONDITIONING CIRCUIT.

Figure 4.1. Front Edge Connector Pin/Signal Orientation

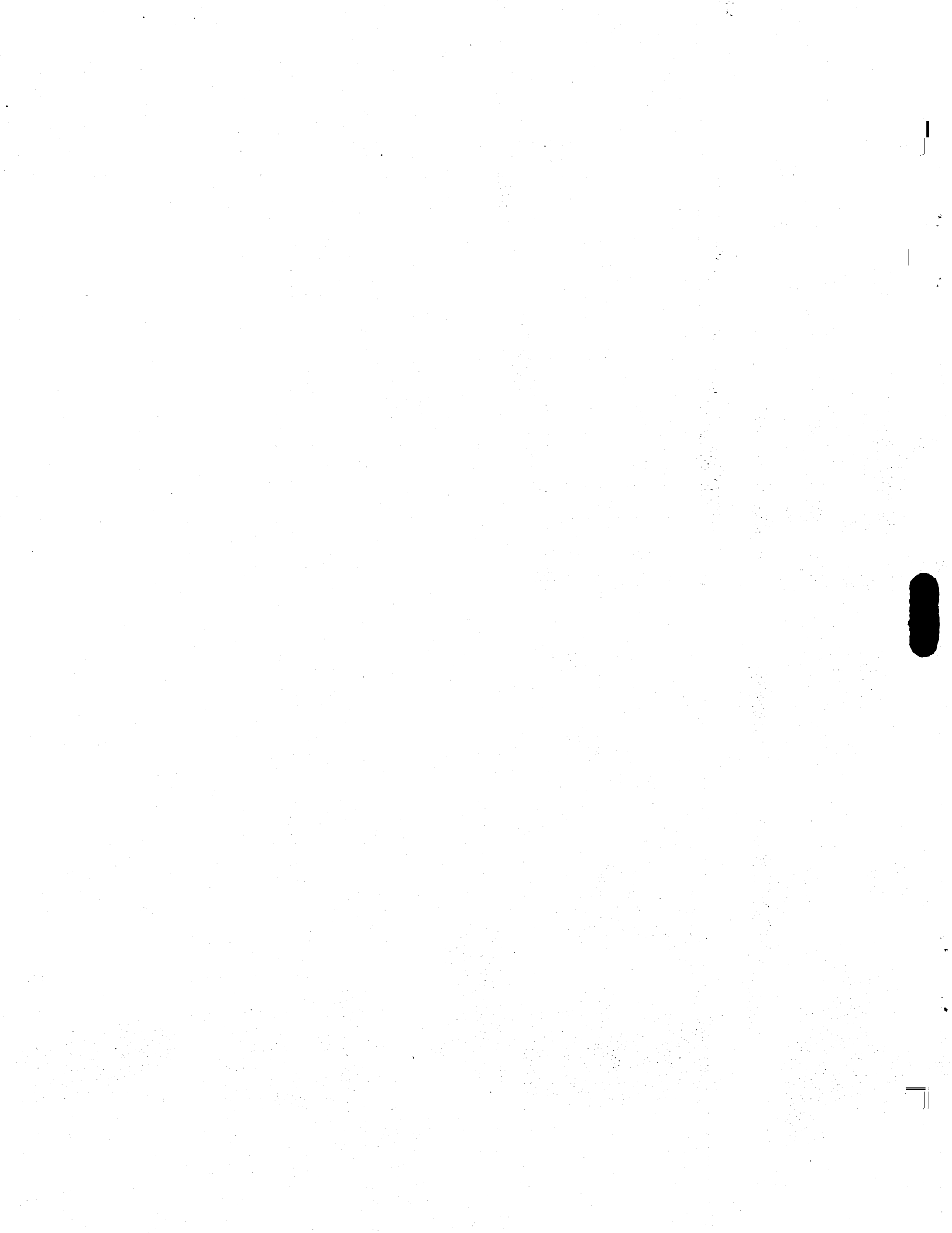

Section Five
DIAGRAMS

5.1 GENERAL

This section contains the following diagrams:

<u>Figure Number</u>	<u>Title</u>
5.1	CIU/CIE Block Diagram
5.2	CIU/CIE Power Wiring Diagram
5.3	CIU Cabling Diagram
5.4	CIU/CIE Bus Cabling
5.5	Data/Control Bus Timing, Write Cycle
5.6	Data Control Bus Timing, Read Cycle
5.7	Data/Control Bus Interface Circuits
5.8	CIU Control Logic Package
5.9	CIE Control Logic Package

5.2 DIAGRAMS

EXTERNAL I/O INTERFACE
(CONNECTOR PER ONE STATION ADDRESS LOCATION)

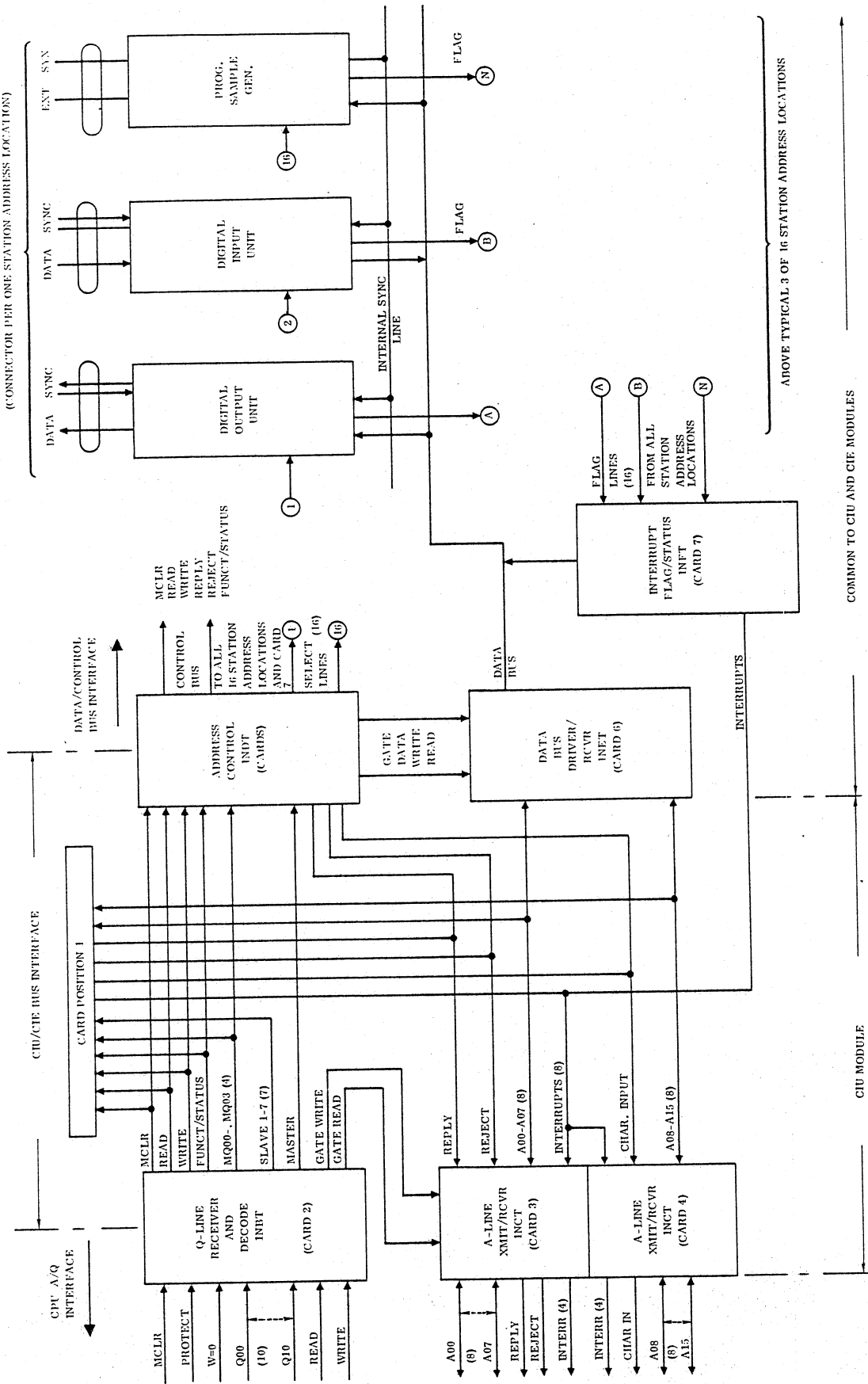

COMMON TO CIU AND CIE MODULES

ABOVE TYPICAL 3 OF 16 STATION ADDRESS LOCATIONS

CIU MODULE

Figure 5.1. CIU/CIE Block Diagram

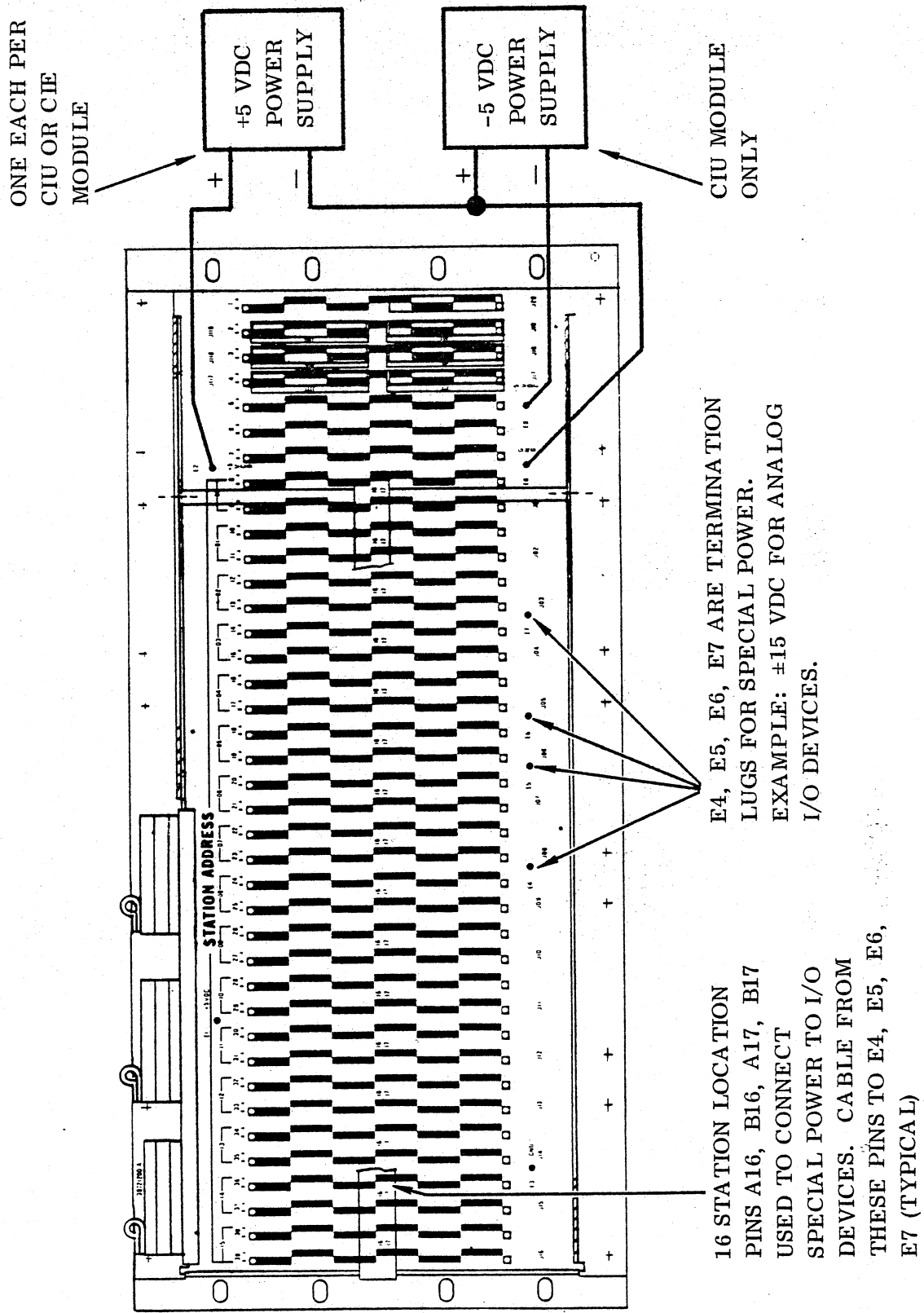
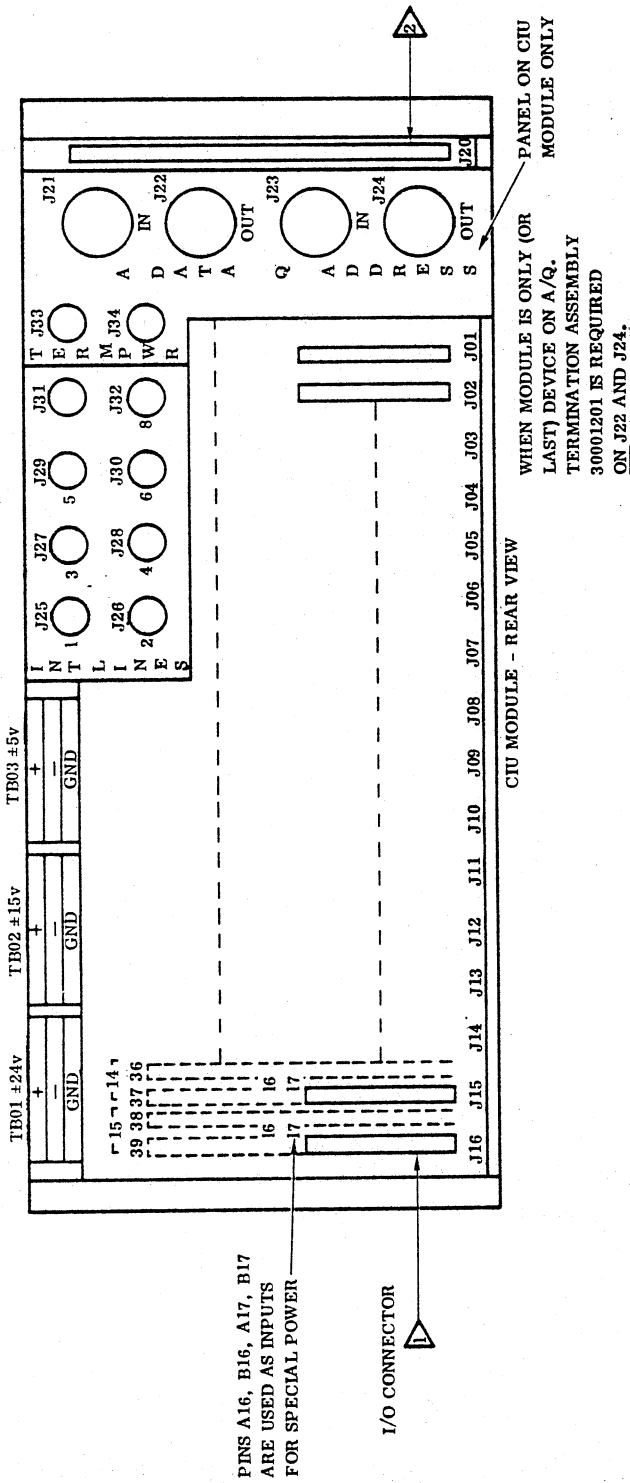

Figure 5.2. CIU/CIE Power Wiring Diagram



CABLE FOR	DESCRIPTION	PART NUMBER	CONSTRUCTION	CONNECTORS	USED ON	LENGTH (MAXIMUM)
J21 - J24	A/Q Cables	10353902	30 Twisted Pair	61-Pin Both Ends	CIU Only	200 Ft.
J25 - J32	Interrupt Cables	388088xx	3-Conductor	3-Pin MS Both Ends	CIU Only	200 Ft.
J33 - J34	Termination Power Cable	390047xx or 38927912	2-Conductor	2-Pin MS One End	CIU Only	200 Ft.
J20	Data Control Bus Interface Cable	39905500 (12") 39905501 (17") 39905502 (68")	30-Twisted Pair Ribbon	62-Pin Board Conn. Both Ends	CIU and CIE	6 Ft.
J01 - J16 (Reference)	External I/O Device Cable	1	Twisted Pair	28-Pin Berg One End	CIU and CIE	1

NOTES:

1. xx The last two digits determine cable length.
2. 1 Called out at system configuration. Cables to be strain-relieved by using panel cutouts.
3. 2 Used when slave modules are connected in system.

Figure 5.3. CIU Cabling Diagram

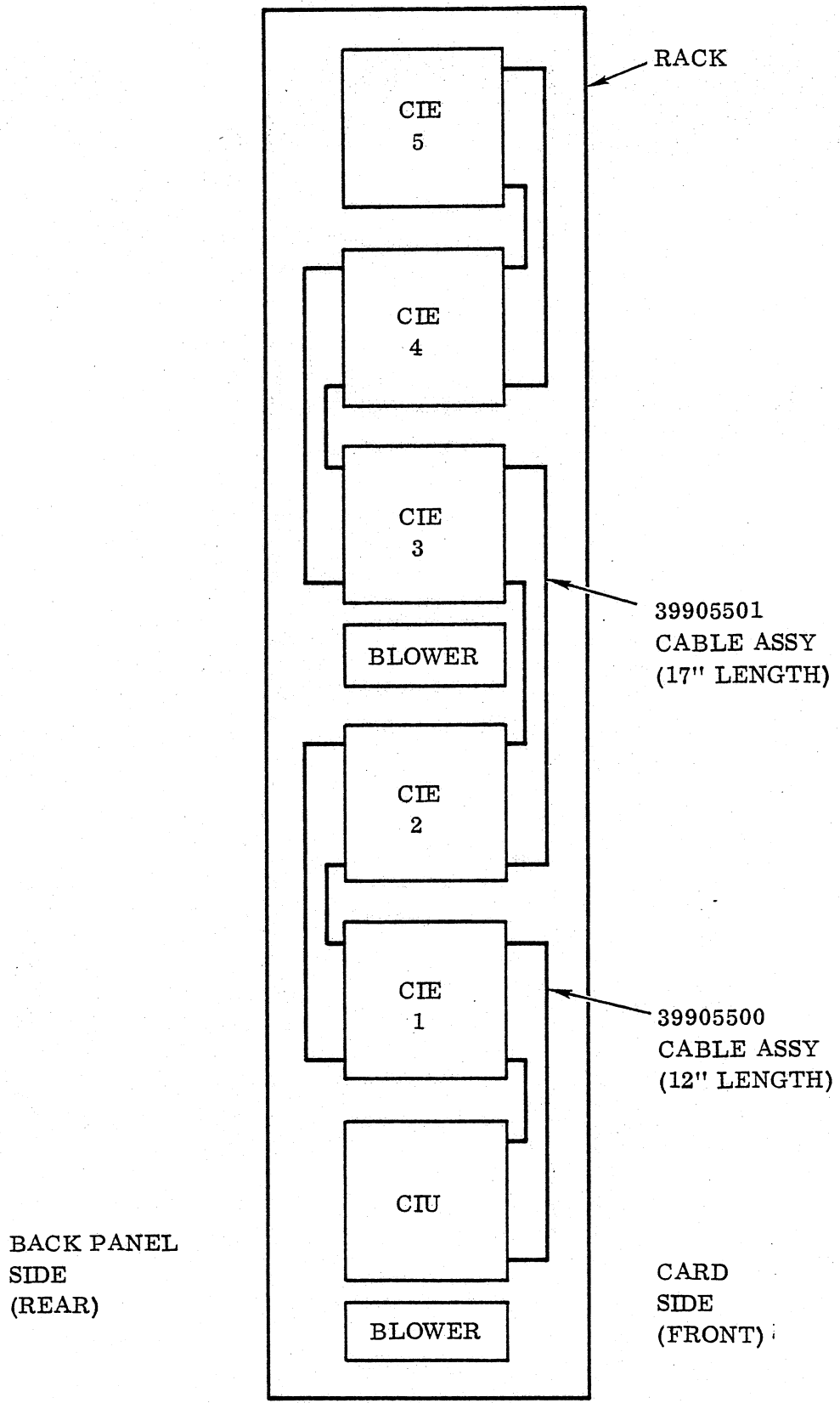

Figure 5.4. CIU/CIE Bus Cabling

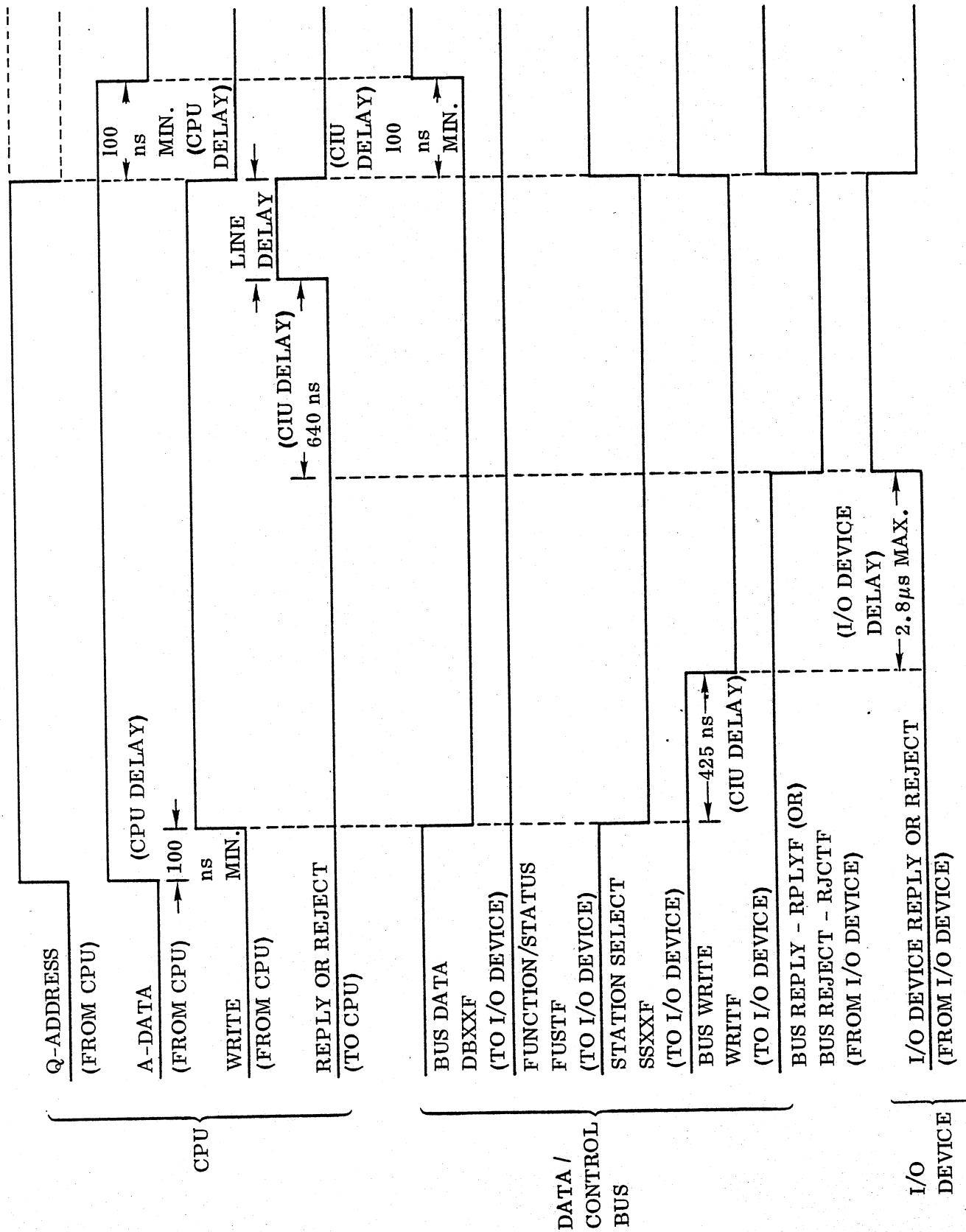

Figure 5.5. Data/Control Bus Timing, Write Cycle

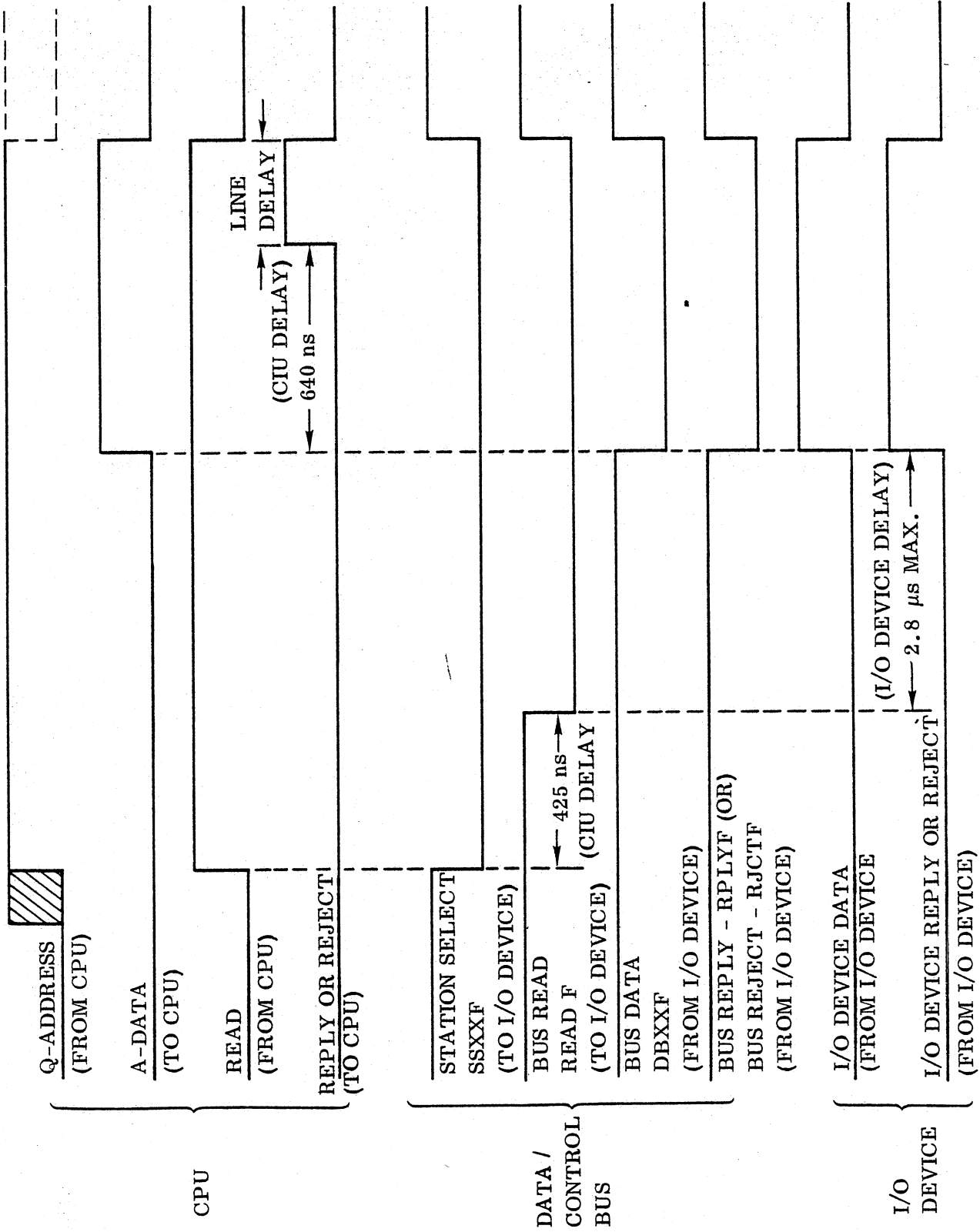
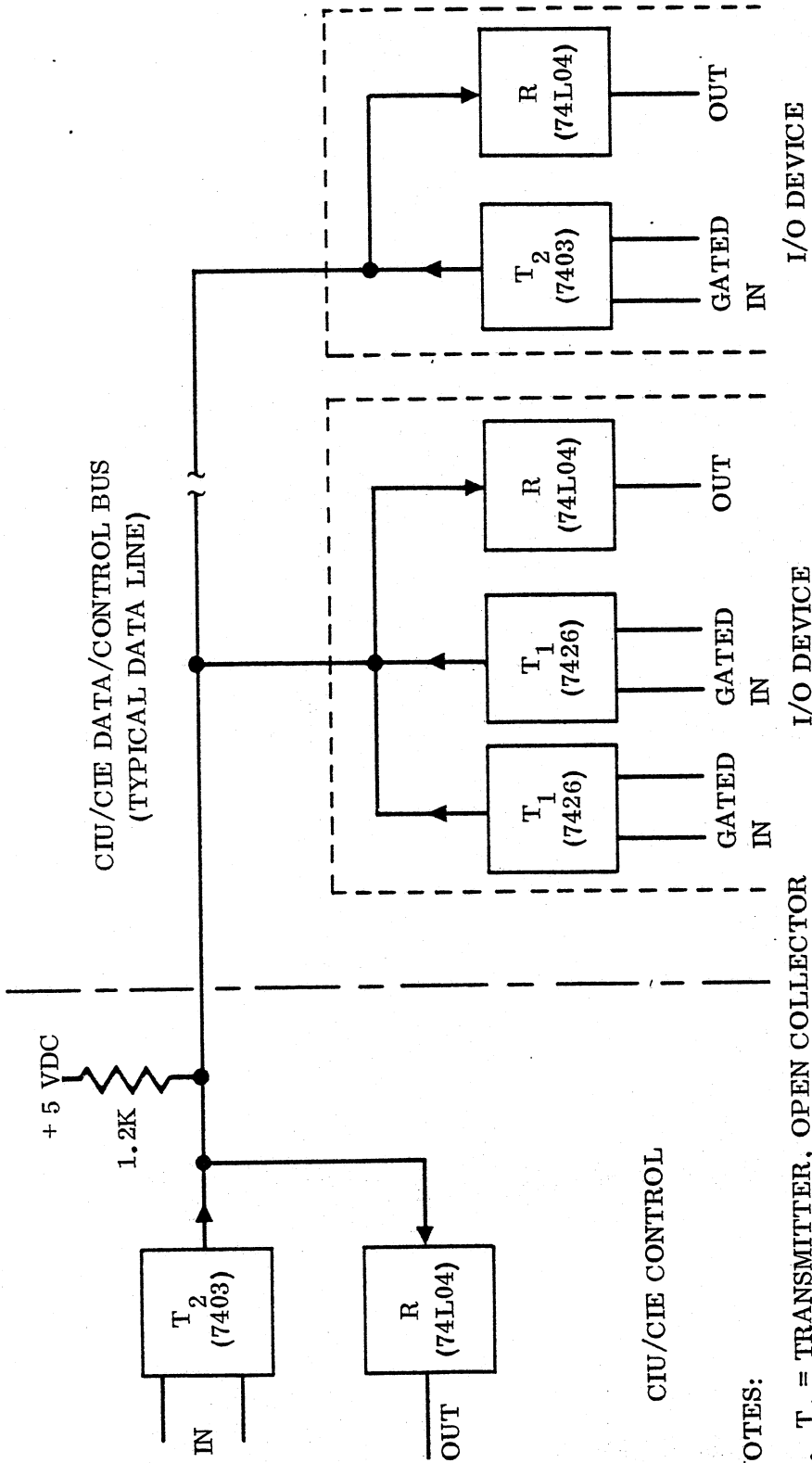

Figure 5.6. Data/Control Bus Timing, Read Cycle



TYPICAL 2 OF 16 DEVICES

NOTES:

1. T₁ = TRANSMITTER, OPEN COLLECTOR NAND GATE (TYPE 7426) WHEN TWO OR MORE ARE TIED TO THE SAME BUS LINE IN ONE I/O DEVICE.
2. T₂ = TRANSMITTER, OPEN COLLECTOR NAND GATE (TYPE 7403) WHEN ONE PER BUS LINE IS USED.
3. R = RECEIVER, LOW POWER NAND HEX INVERTER (TYPE 74L04)

Figure 5.7. Data/Control Bus Interface Circuits

Figure 5.8. CIU Control Logic Package

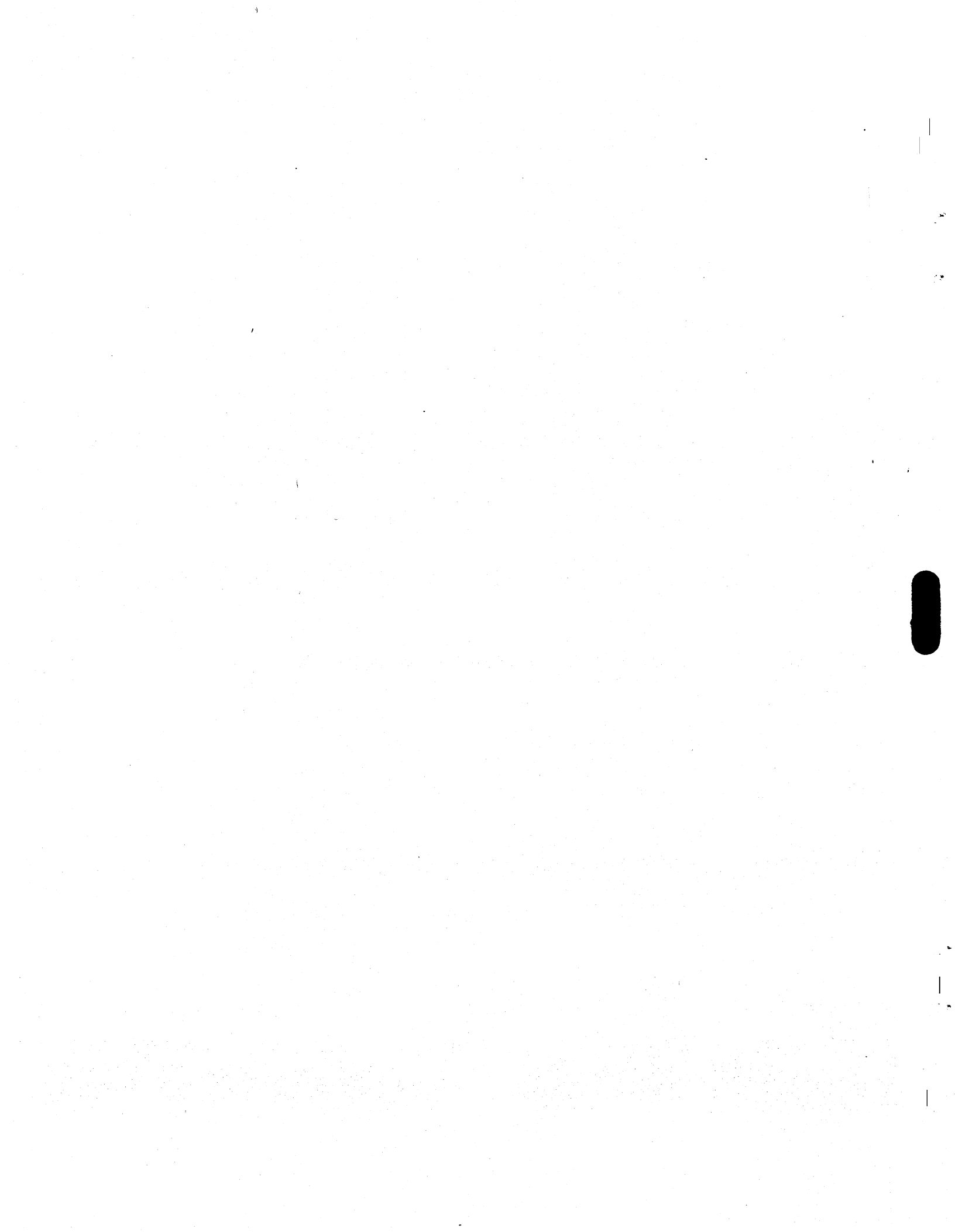

REV	ECO	DESCRIPTION	DATE	CHK	APP
01		PRE P.L.T.	2-4-72		
A	DDC	ECR 4 TIO	10-30-72		
B	13169	REVISED SMT 2 PER ECO	6-19-72		
C	13174	CHG'D SMT 3 PER ECO	11-21-72		
D	13186	CHG'D SMT 5 & 8 PER ECO	4-11-74		
E	13221	CHG'D SMT 15 PER ECO	1-22-74		
F	13402	CHG'D SMT 1 PER ECO	1-22-74		
G	13412	ADDED #9 ON SMT 11	7-13-74		

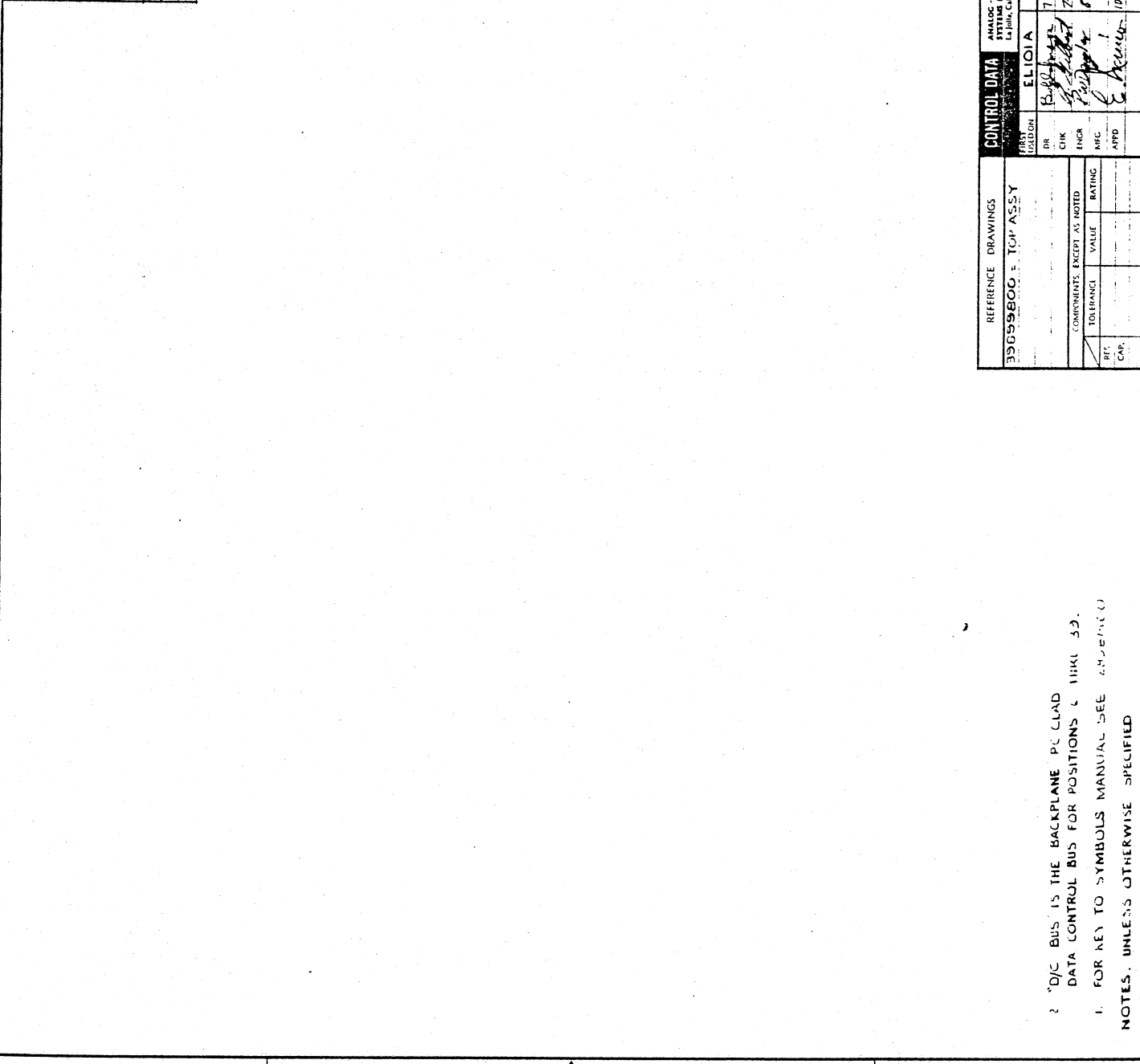

**LOGIC DIAGRAM -
COMPUTER INTERFACE UNIT**

DRAWING NUMBER
39904700

CODE IDENT NO
C 09132

SHEET 1 OF 15

REFERENCE DRAWINGS
3999800 - TOP ASSY

CONTROL DATA
ANALOG - DIGITAL SYSTEMS DIVISION
La Jolla, Calif. 92037

ELIOIA

DESIGNER	7-18-74
CHK	7-24-74
ENGR	8-4-74
APPD	10-30-74

COMPONENTS EXCEPT AS NOTED

TOLERANCE	VALUE	RATING
RFC		
CAP		

1. D/C BUS IS THE BACKPLANE P.C. LEAD
DATA CONTROL BUS FOR POSITIONS C 111K1 32.

2. FOR KEY TO SYMBOLS MANUAL SEE 399274(C)

NOTES: UNLESS OTHERWISE SPECIFIED

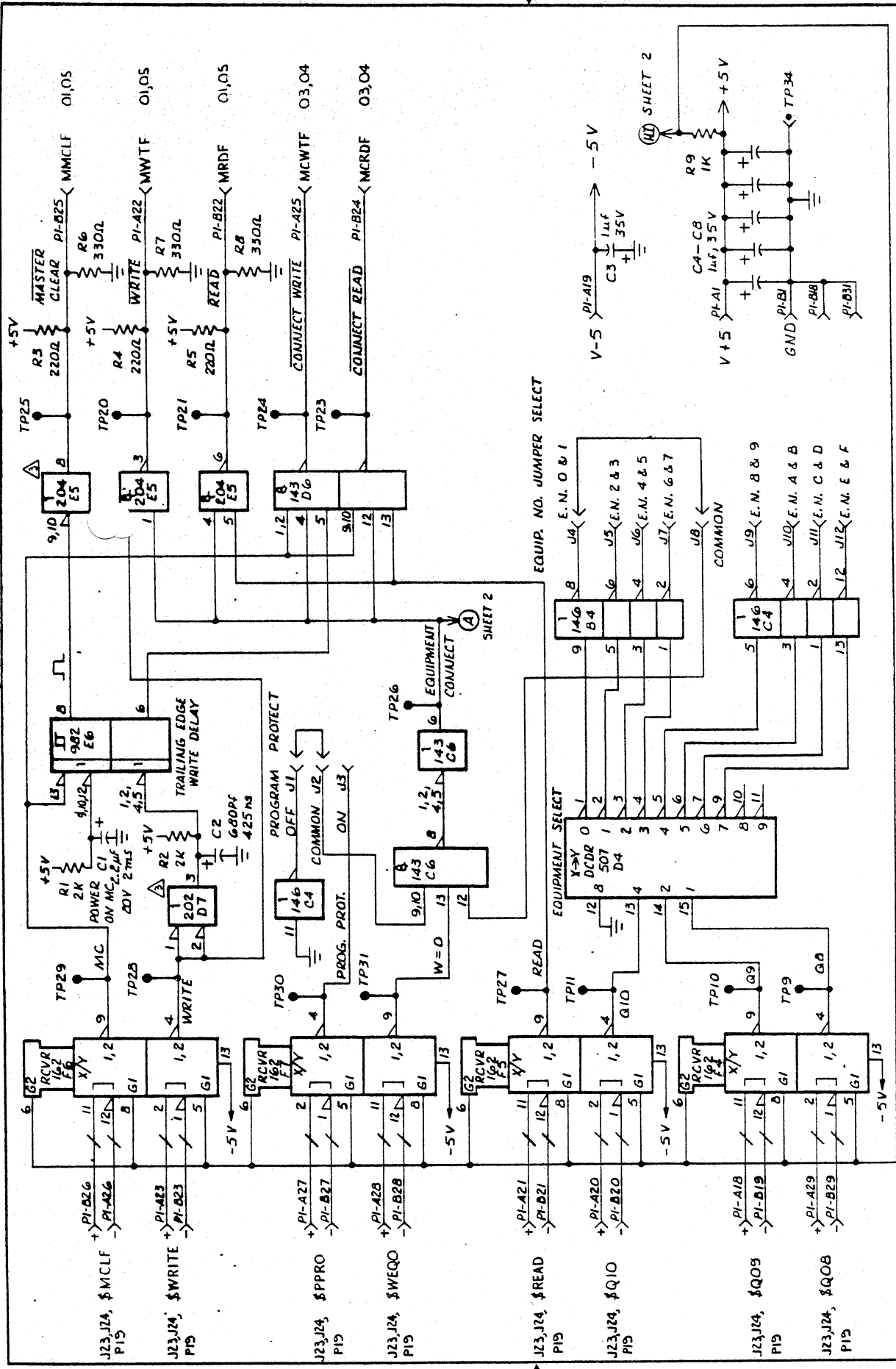

DETAILED LIST		Q-LINE RECEIVERS & DECODE							CONTROL DATA		TITLE		CARD POS
Q	LINE	A	B	C	D	E	F	ANALOG - DIGITAL	ANALOG - DIGITAL	LOGIC TYPE	LOGIC TYPE		
1	162	7404	7442	7438	75107	75107	75107	ELIOLIA & ELIOLIA	ELIOLIA & ELIOLIA	INBT	INBT	02	
2	163	7404	7438	75107	75107	75107	75107	ELIOLIA & ELIOLIA	ELIOLIA & ELIOLIA	INBT	INBT	02	
3	164	7404	7438	75107	75107	75107	75107	ELIOLIA & ELIOLIA	ELIOLIA & ELIOLIA	INBT	INBT	02	
4	165	7404	7438	75107	75107	75107	75107	ELIOLIA & ELIOLIA	ELIOLIA & ELIOLIA	INBT	INBT	02	
5	166	7404	7438	75107	75107	75107	75107	ELIOLIA & ELIOLIA	ELIOLIA & ELIOLIA	INBT	INBT	02	
6	167	7404	7438	75107	75107	75107	75107	ELIOLIA & ELIOLIA	ELIOLIA & ELIOLIA	INBT	INBT	02	
7	168	7404	7438	75107	75107	75107	75107	ELIOLIA & ELIOLIA	ELIOLIA & ELIOLIA	INBT	INBT	02	

39840200	39840100	39840000
39840200	39840100	39840000
39840200	39840100	39840000

09132	39840700	C
09132	39840700	C
09132	39840700	C

ALL ELEMENT IDENTIFIERS 202 (204 ARE OPEN COLLECTOR).

2. I C C * & D7 ARE NOT COMPLETELY USED.

1. ALL RESISTORS ARE 1/4 W.

NOTES UNLESS OTHERWISE SPECIFIED

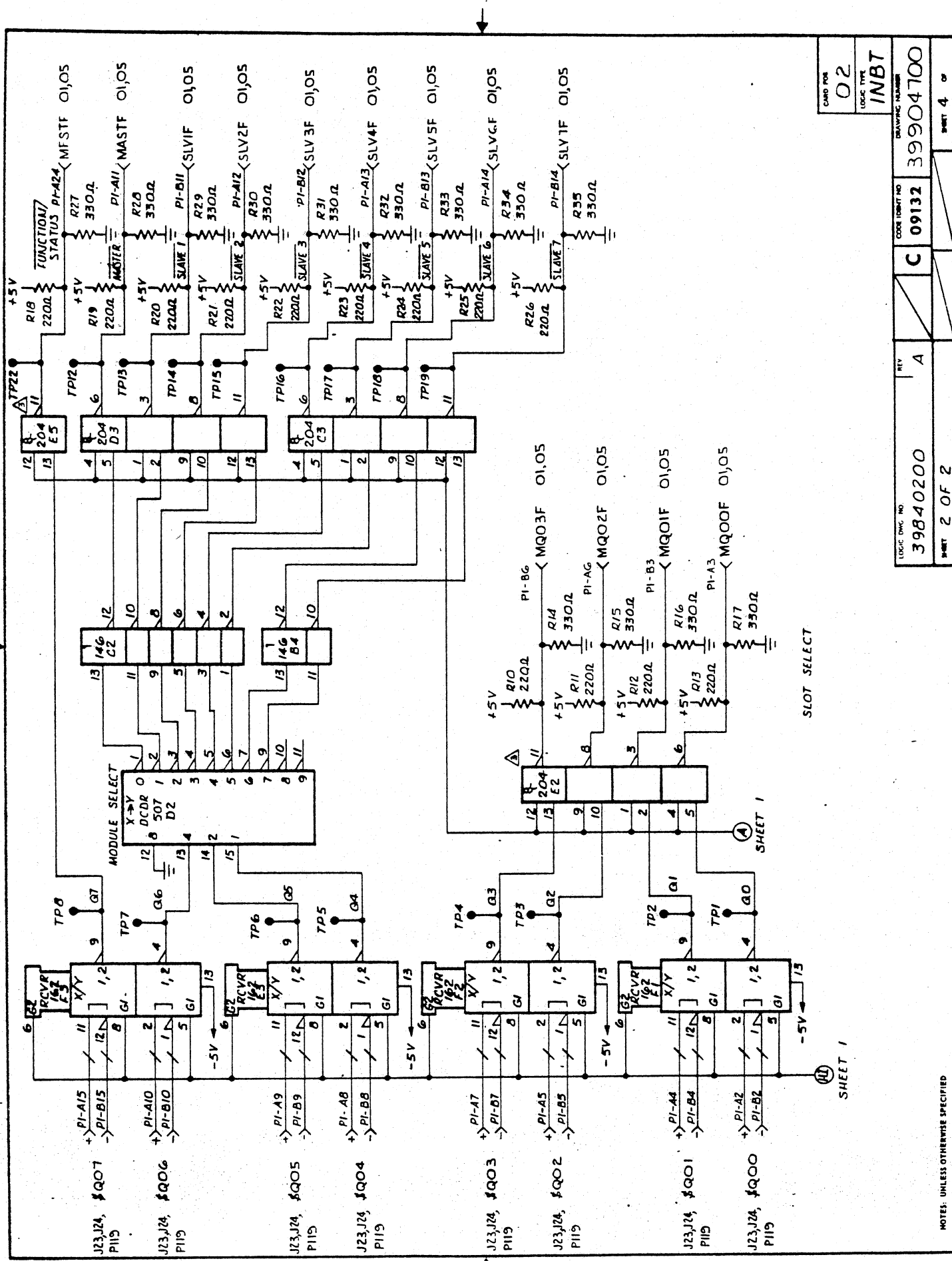

CARD NO
02

LOGIC TYPE
INBT

LOGIC DWG NO
39840200

REV
A

CODE IDENT NO
C 09132

DRAWING NUMBER
39904700

SHEET 4 OF

LOGIC DWG NO
39840200

REV
A

CODE IDENT NO
C 09132

DRAWING NUMBER
39904700

SHEET 2 OF 2

NOTES: UNLESS OTHERWISE SPECIFIED

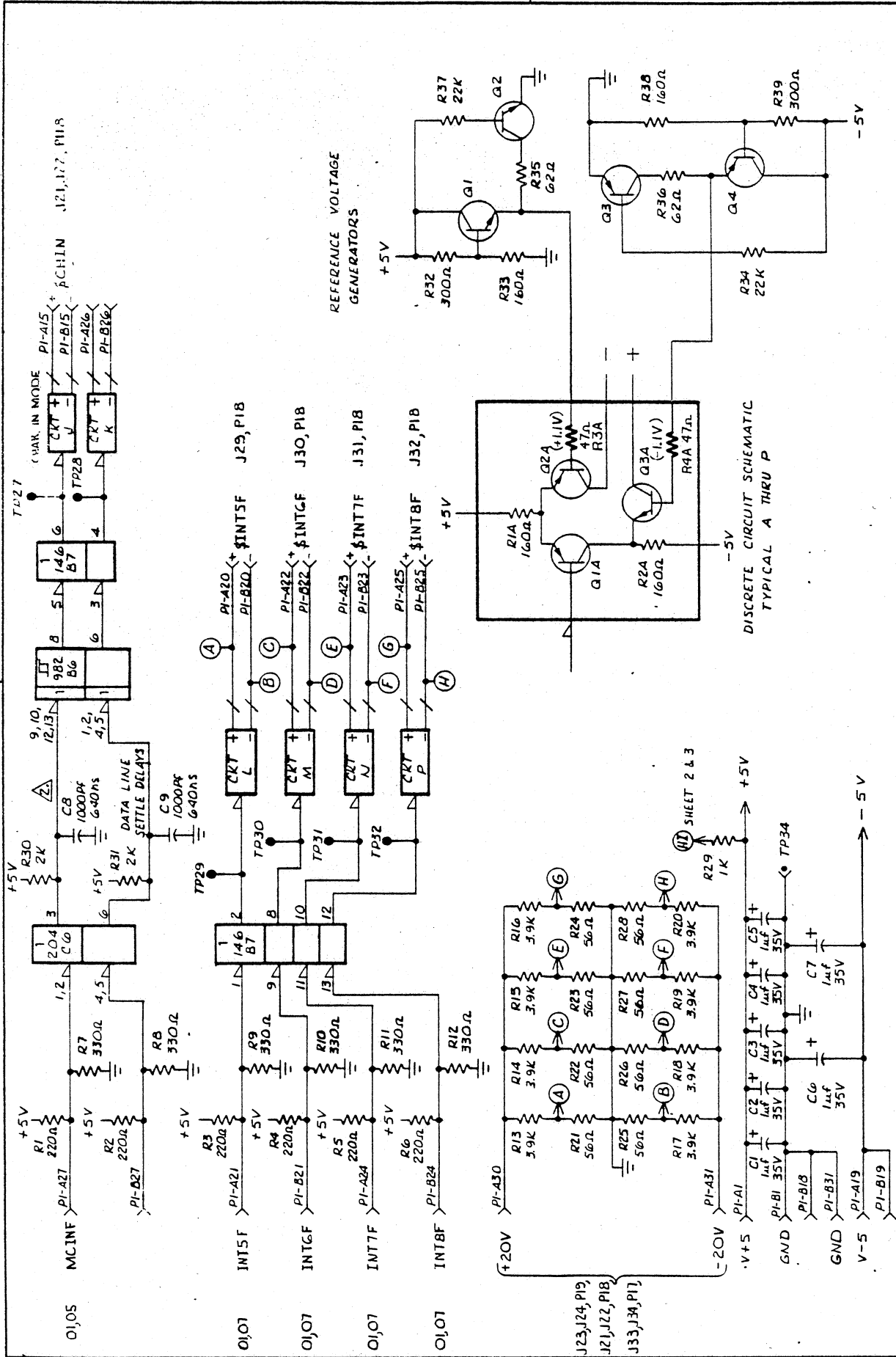

REFERENCE VOLTAGE GENERATORS

DISCRETE CIRCUIT SCHEMATIC TYPICAL A THRU P

DR 9840500							DETTACHED LIST						
A	B	C	D	E	F		A	B	C	D	E	F	
1	7400	7404					1	7400	7404				
2	74104	7438	75107	75107			2	74104	7438	75107	75107		
3	74104	7438	75107	75107			3	74104	7438	75107	75107		
4	7400	7404					4	7400	7404				
5	7413	7438					5	7413	7438				
6							6						
7							7						

LOGIC TITLE	A - LINE TRANSMITTER / RECEIVER	
ANALOG - DIGITAL SYSTEMS DIVISION	LIDA & ELIOZA	
DATE	4 7 72	7 11 72
DR	J. J. ...	J. J. ...
CHK	J. J. ...	J. J. ...
ENG	J. J. ...	J. J. ...
MIC	J. J. ...	J. J. ...
APPD	J. J. ...	J. J. ...
REV	1 OF 3	3
PWB NO	39840400	39840300

TITLE	A - LINE TRANSMITTER RECEIVER	
LOGIC TYPE	BITS 00 - 01	
CARD POS	03	
DRAWING NUMBER	INCT	
CORE IDENT NO	C 09132	
DRAWING NUMBER	39904100	
SHEET	5 OF	

ALL ELEMENT IDENTIFIER 204 ARE OPEN COLLECTOR.
 1. ALL RESISTORS ARE 1/4 W.
 NOTES UNLESS OTHERWISE SPECIFIED

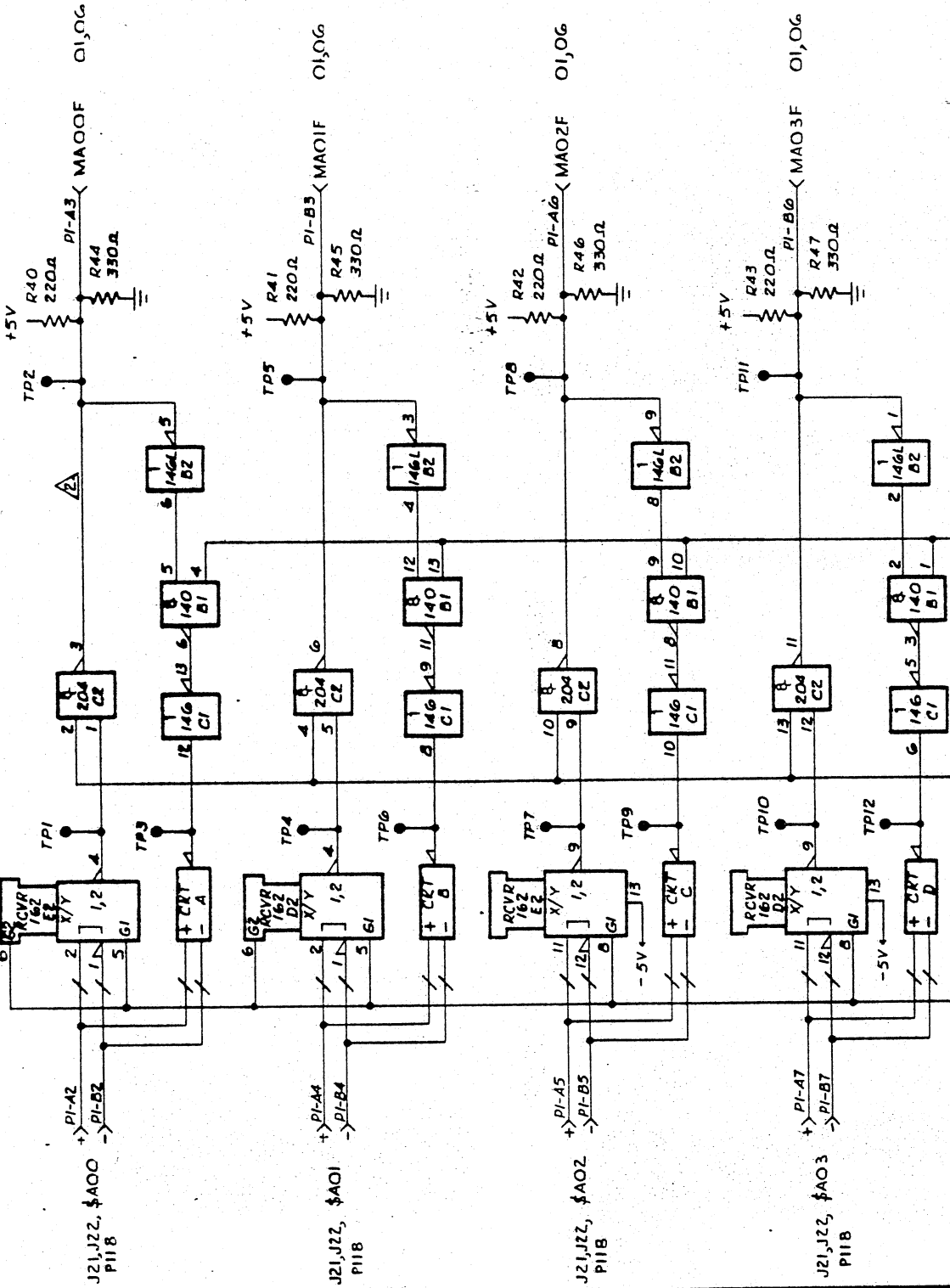

SHEET 3

SHEET 3

SHEET 1

NOTES: UNLESS OTHERWISE SPECIFIED

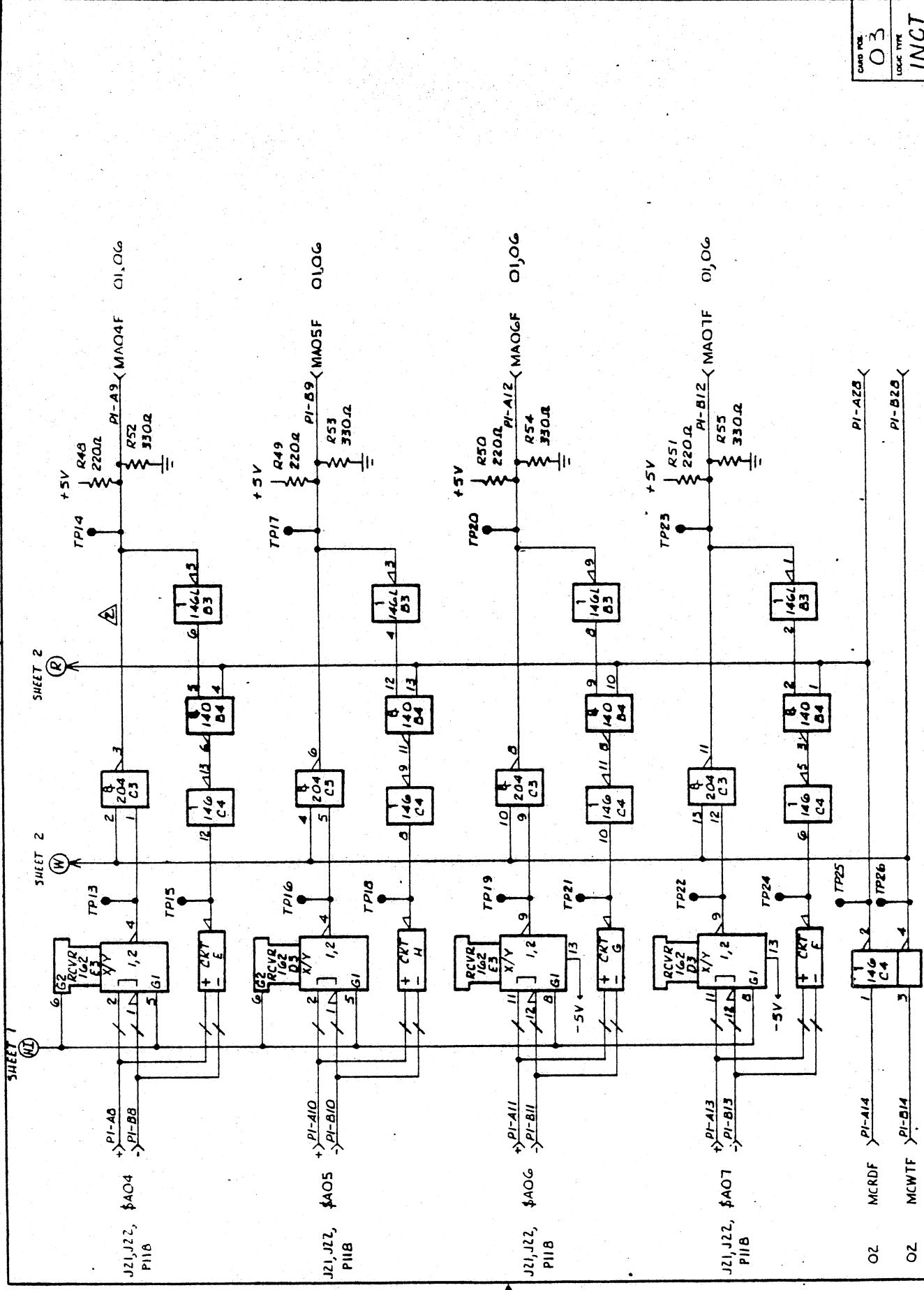

CARD NO. 03
 LOGIC TYPE INCT
 DRAWING NUMBER 39904700
 SHEET 7 OF

CODE IDENT NO. C 09132

REV. A

LOGIC DWG. NO. 39840500
 SHEET 3 OF 3

NOTES: UNLESS OTHERWISE SPECIFIED

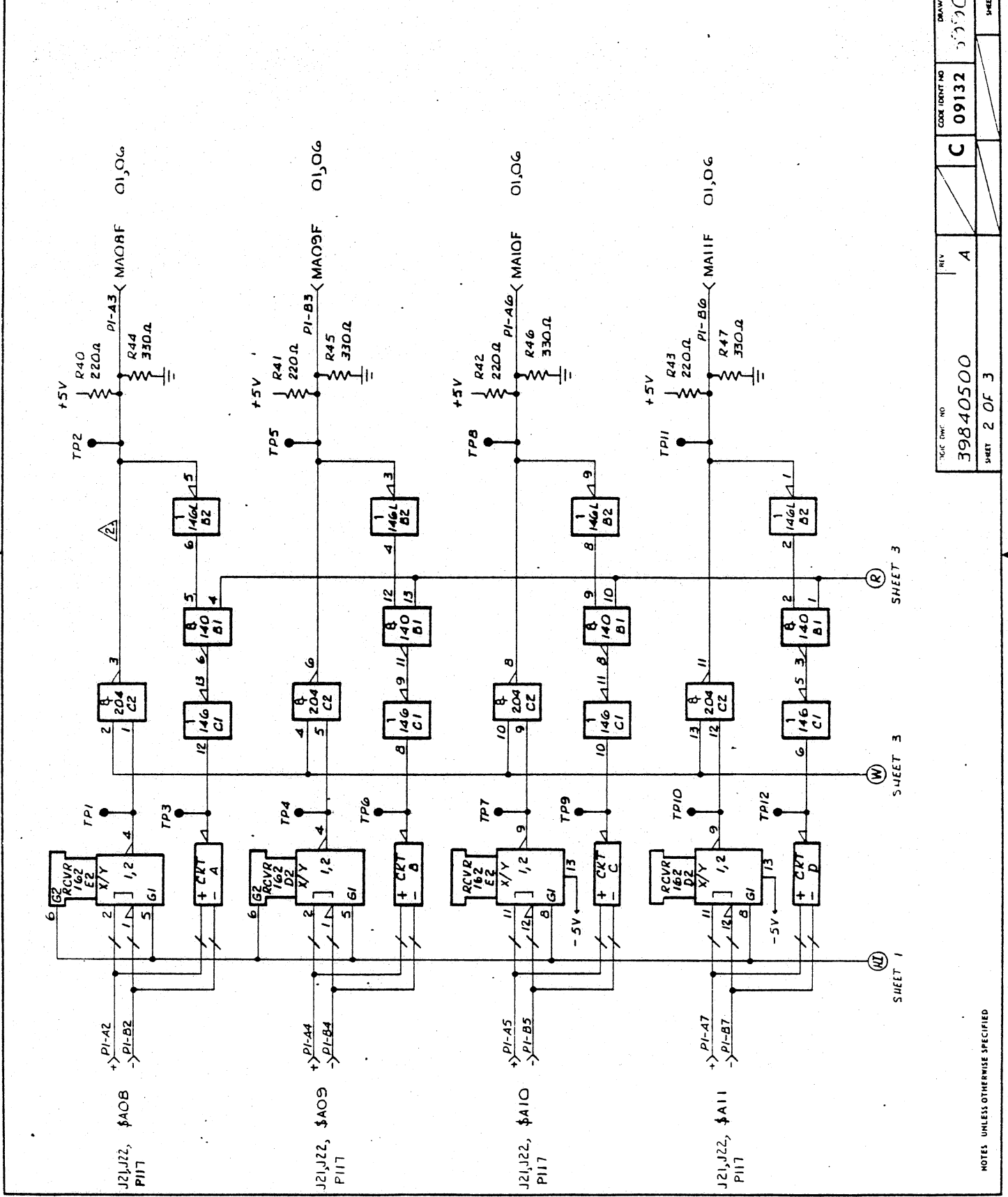

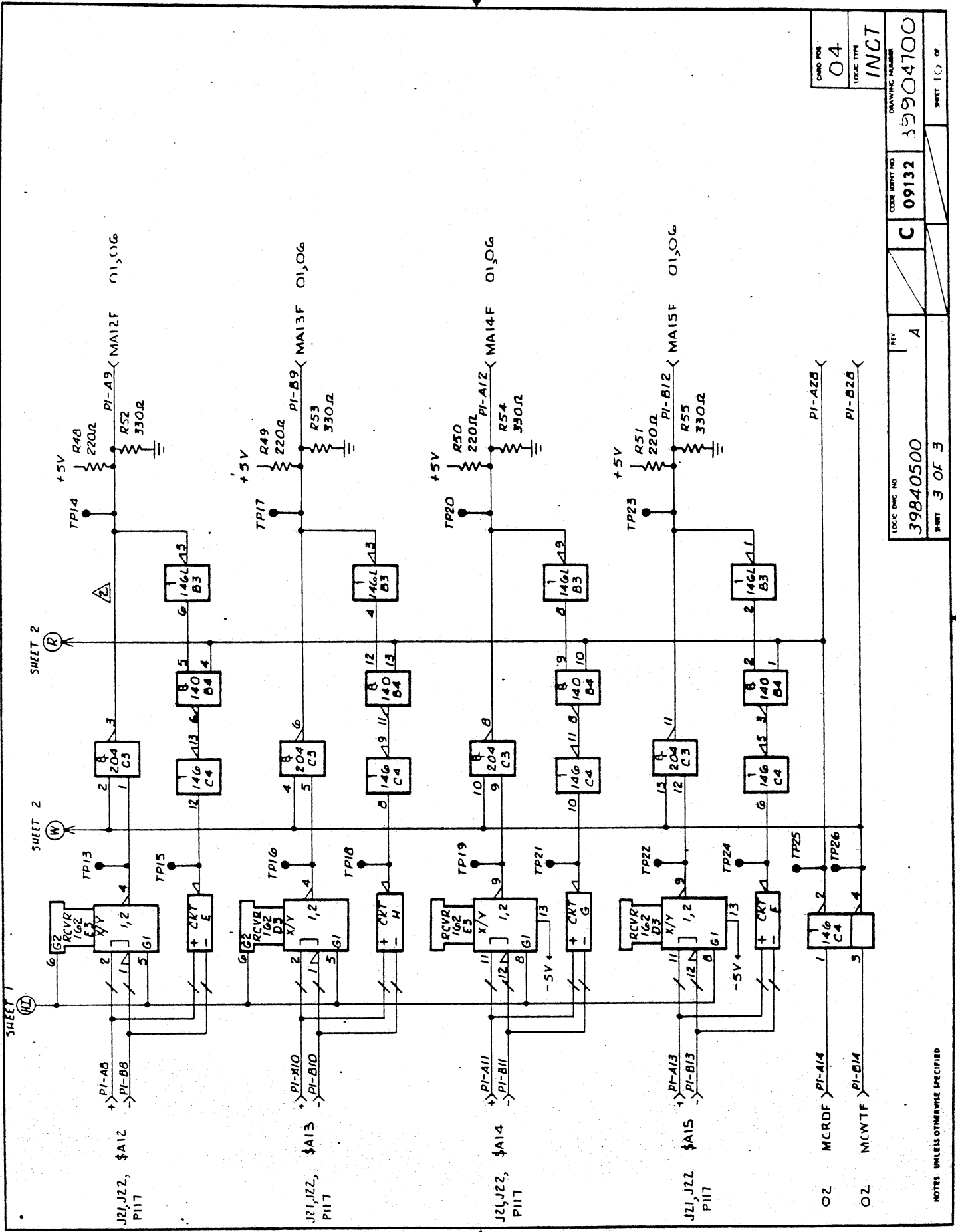

LOGIC DWG. NO.	REV.	CODE IDENT. NO.	DRAWING NUMBER	SHEET 10 OF
39840500	A	C 09132	39904700	
SHEET 3 OF 3		LOGIC TYPE		
		INCT		
		CARD NOS		
		04		

NOTES: UNLESS OTHERWISE SPECIFIED

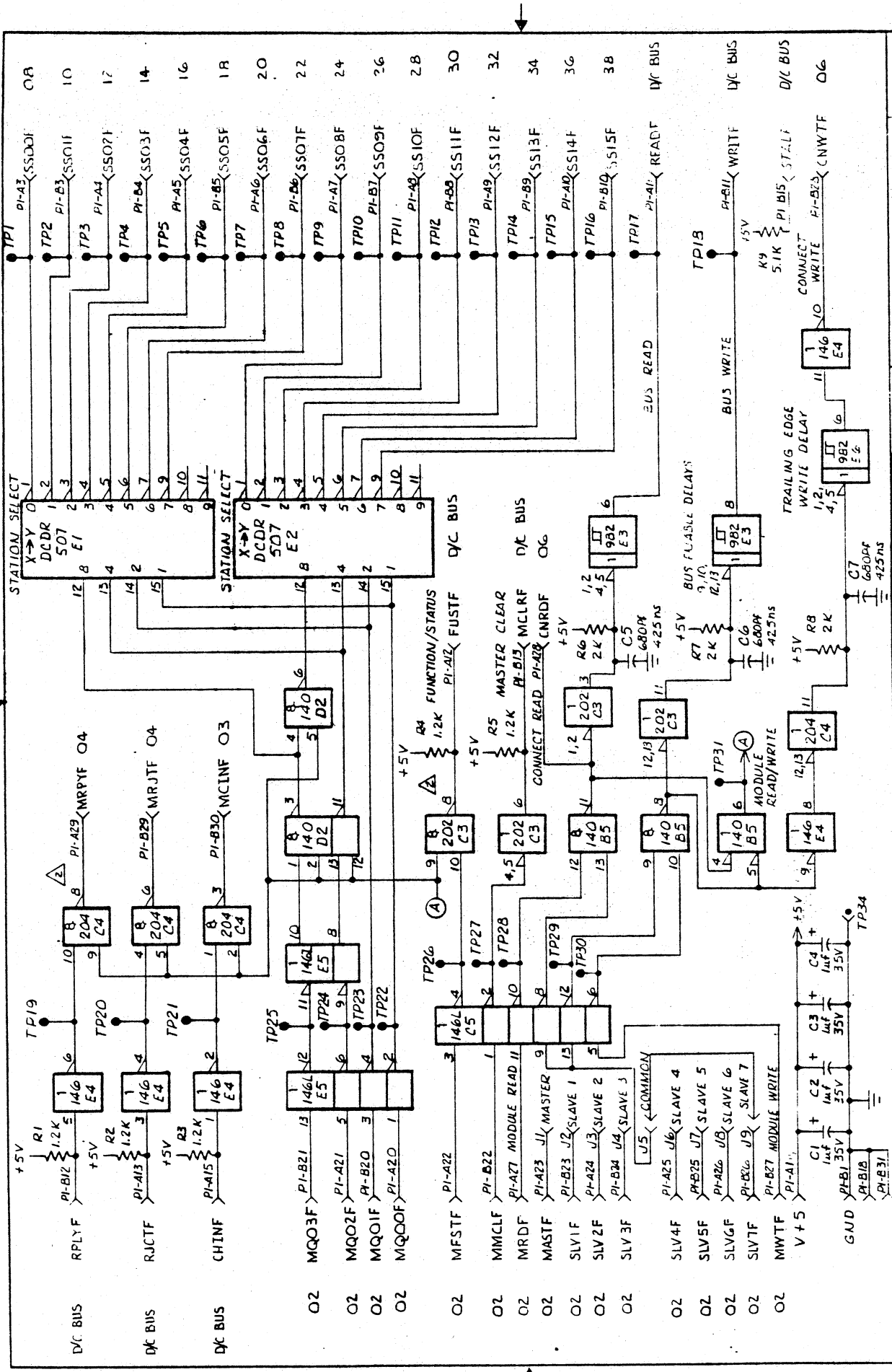

CONTROL DATA ANALOG-DIGITAL SYSTEMS DIVISION ELECTRONIC SYSTEMS GROUP 5-5172 DATE: 1/10/70 DRAWN: [Signature] CHECKED: [Signature] APPROVED: [Signature]							ADDRESS CONTROL 39840800 SHT 1 OF 1 A 39840700 3 3040600							STATION ADDRESS CONTROL / DECODE CARD POS 05 ISSUE TYPE INDT COORDINATE NO C 09132 WORK NO 30017006 SHEET 11 OF 20																																																																																																																																																																																																																																																																																																																																																																																																																																																																																																																																																																																																																																																																																																																																																																																																																																																																																																																																																																																																																																																																																																																																																																																																																																																																																																																																																																																																											
1	2	3	4	5	6	7	8	9	10	11	12	13	14	15	16	17	18	19	20	21	22	23	24	25	26	27	28	29	30	31	32	33	34	35	36	37	38	39	40	41	42	43	44	45	46	47	48	49	50	51	52	53	54	55	56	57	58	59	60	61	62	63	64	65	66	67	68	69	70	71	72	73	74	75	76	77	78	79	80	81	82	83	84	85	86	87	88	89	90	91	92	93	94	95	96	97	98	99	100	101	102	103	104	105	106	107	108	109	110	111	112	113	114	115	116	117	118	119	120	121	122	123	124	125	126	127	128	129	130	131	132	133	134	135	136	137	138	139	140	141	142	143	144	145	146	147	148	149	150	151	152	153	154	155	156	157	158	159	160	161	162	163	164	165	166	167	168	169	170	171	172	173	174	175	176	177	178	179	180	181	182	183	184	185	186	187	188	189	190	191	192	193	194	195	196	197	198	199	200	201	202	203	204	205	206	207	208	209	210	211	212	213	214	215	216	217	218	219	220	221	222	223	224	225	226	227	228	229	230	231	232	233	234	235	236	237	238	239	240	241	242	243	244	245	246	247	248	249	250	251	252	253	254	255	256	257	258	259	260	261	262	263	264	265	266	267	268	269	270	271	272	273	274	275	276	277	278	279	280	281	282	283	284	285	286	287	288	289	290	291	292	293	294	295	296	297	298	299	300	301	302	303	304	305	306	307	308	309	310	311	312	313	314	315	316	317	318	319	320	321	322	323	324	325	326	327	328	329	330	331	332	333	334	335	336	337	338	339	340	341	342	343	344	345	346	347	348	349	350	351	352	353	354	355	356	357	358	359	360	361	362	363	364	365	366	367	368	369	370	371	372	373	374	375	376	377	378	379	380	381	382	383	384	385	386	387	388	389	390	391	392	393	394	395	396	397	398	399	400	401	402	403	404	405	406	407	408	409	410	411	412	413	414	415	416	417	418	419	420	421	422	423	424	425	426	427	428	429	430	431	432	433	434	435	436	437	438	439	440	441	442	443	444	445	446	447	448	449	450	451	452	453	454	455	456	457	458	459	460	461	462	463	464	465	466	467	468	469	470	471	472	473	474	475	476	477	478	479	480	481	482	483	484	485	486	487	488	489	490	491	492	493	494	495	496	497	498	499	500	501	502	503	504	505	506	507	508	509	510	511	512	513	514	515	516	517	518	519	520	521	522	523	524	525	526	527	528	529	530	531	532	533	534	535	536	537	538	539	540	541	542	543	544	545	546	547	548	549	550	551	552	553	554	555	556	557	558	559	560	561	562	563	564	565	566	567	568	569	570	571	572	573	574	575	576	577	578	579	580	581	582	583	584	585	586	587	588	589	590	591	592	593	594	595	596	597	598	599	600	601	602	603	604	605	606	607	608	609	610	611	612	613	614	615	616	617	618	619	620	621	622	623	624	625	626	627	628	629	630	631	632	633	634	635	636	637	638	639	640	641	642	643	644	645	646	647	648	649	650	651	652	653	654	655	656	657	658	659	660	661	662	663	664	665	666	667	668	669	670	671	672	673	674	675	676	677	678	679	680	681	682	683	684	685	686	687	688	689	690	691	692	693	694	695	696	697	698	699	700	701	702	703	704	705	706	707	708	709	710	711	712	713	714	715	716	717	718	719	720	721	722	723	724	725	726	727	728	729	730	731	732	733	734	735	736	737	738	739	740	741	742	743	744	745	746	747	748	749	750	751	752	753	754	755	756	757	758	759	760	761	762	763	764	765	766	767	768	769	770	771	772	773	774	775	776	777	778	779	780	781	782	783	784	785	786	787	788	789	790	791	792	793	794	795	796	797	798	799	800	801	802	803	804	805	806	807	808	809	810	811	812	813	814	815	816	817	818	819	820	821	822	823	824	825	826	827	828	829	830	831	832	833	834	835	836	837	838	839	840	841	842	843	844	845	846	847	848	849	850	851	852	853	854	855	856	857	858	859	860	861	862	863	864	865	866	867	868	869	870	871	872	873	874	875	876	877	878	879	880	881	882	883	884	885	886	887	888	889	890	891	892	893	894	895	896	897	898	899	900	901	902	903	904	905	906	907	908	909	910	911	912	913	914	915	916	917	918	919	920	921	922	923	924	925	926	927	928	929	930	931	932	933	934	935	936	937	938	939	940	941	942	943	944	945	946	947	948	949	950	951	952	953	954	955	956	957	958	959	960	961	962	963	964	965	966	967	968	969	970	971	972	973	974	975	976	977	978	979	980	981	982	983	984	985	986	987	988	989	990	991	992	993	994	995	996	997	998	999	1000	1001	1002	1003	1004	1005	1006	1007	1008	1009	1010	1011	1012	1013	1014	1015	1016	1017	1018	1019	1020	1021	1022	1023	1024	1025	1026	1027	1028	1029	1030	1031	1032	1033	1034	1035	1036	1037	1038	1039	1040	1041	1042	1043	1044	1045	1046	1047	1048	1049	1050	1051	1052	1053	1054	1055	1056	1057	1058	1059	1060	1061	1062	1063	1064	1065	1066	1067	1068	1069	1070	1071	1072	1073	1074	1075	1076	1077	1078	1079	1080	1081	1082	1083	1084	1085	1086	1087	1088	1089	1090	1091	1092	1093	1094	1095	1096	1097	1098	1099	1100	1101	1102	1103	1104	1105	1106	1107	1108	1109	1110	1111	1112	1113	1114	1115	1116	1117	1118	1119	1120	1121	1122	1123	1124	1125	1126	1127	1128	1129	1130	1131	1132	1133	1134	1135	1136	1137	1138	1139	1140	1141	1142	1143	1144	1145	1146	1147	1148	1149	1150	1151	1152	1153	1154	1155	1156	1157	1158	1159	1160	1161	1162	1163	1164	1165	1166	1167	1168	1169	1170	1171	1172	1173	1174	1175	1176	1177	1178	1179	1180	1181	1182	1183	1184	1185	1186	1187	1188	1189	1190	1191	1192	1193	1194	1195	1196	1197	1198	1199	1200	1201	1202	1203	1204	1205	1206	1207	1208	1209	1210	1211	1212	1213	1214	1215	1216	1217	1218	1219	1220	1221	1222	1223	1224	1225	1226	1227	1228	1229	1230	1231	1232	1233	1234	1235	1236	1237	1238	1239	1240	1241	1242	1243	1244	1245	1246	1247	1248	1249	1250	1251	1252	1253	1254	1255	1256	1257	1258	1259	1260	1261	1262	1263	1264	1265	1266	1267	1268	1269	1270	1271	1272	1273	1274	1275	1276	1277	1278	1279	1280	1281	1282	1283	1284	1285	1286	1287	1288	1289	1290	1291	1292	1293	1294	1295	1296	1297	1298	1299	1300	1301	1302	1303	1304	1305	1306	1307	1308	1309	1310	1311	1312	1313	1314	1315	1316	1317	1318	1319	1320	1321	1322	1323	1324	1325	1326	1327	1328	1329	1330	1331	1332	1333	1334	1335	1336	1337	1338	1339	1340	1341	1342	1343	1344	1345	1346	1347	1348	1349	1350	1351	1352	1353	1354	1355	1356	1357	1358	1359	1360	1361	1362	1363	1364	1365	1366	1367	1368	1369	1370

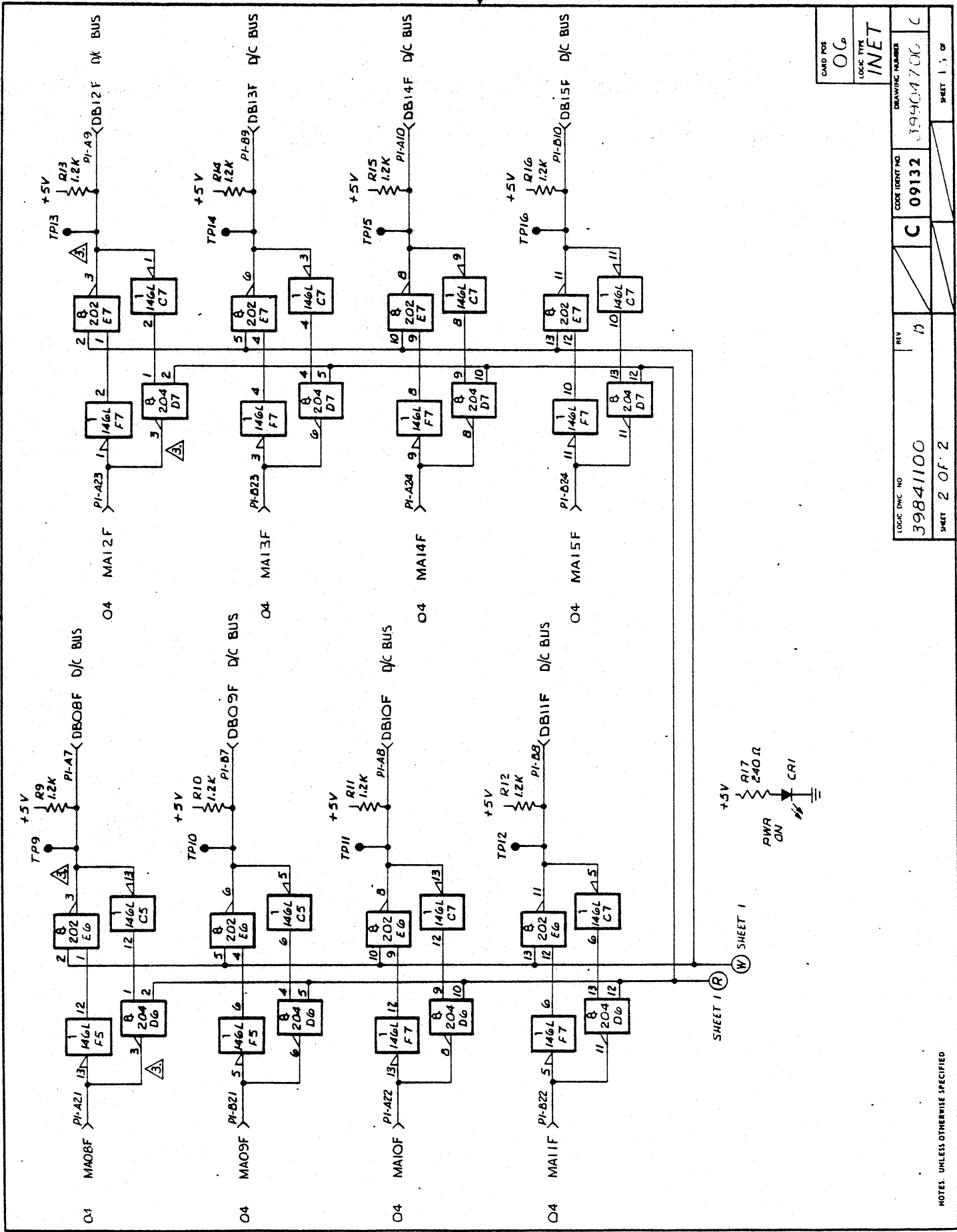

CARD POS	06
LOGIC TYPE	INET
LOGIC DMC NO	39841100
CODE IDENT NO	C 09132
DRAWING NUMBER	39904700
REV	B
SHEET	2 OF 2
SHEET	1 OF 1

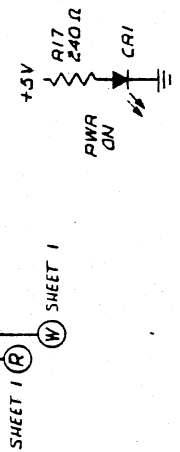

NOTES: UNLESS OTHERWISE SPECIFIED

INTERRUPT LINES

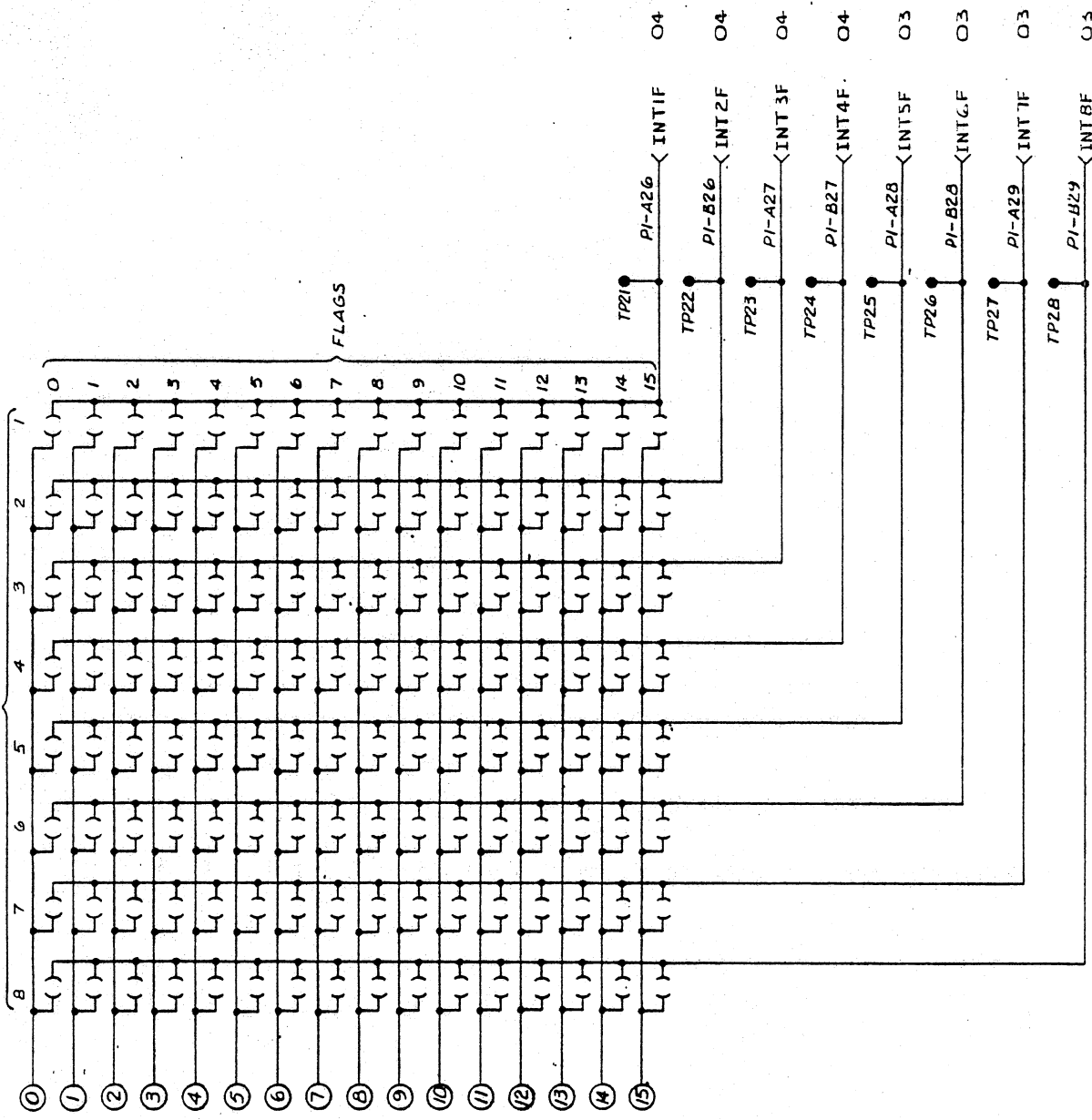

- (•)
- (•)
- (•)
- (•)
- (•)
- (•)
- (•)
- (•)
- (•)
- (•)
- (•)
- (•)
- (•)
- (•)
- (•)

BOLTS & NUTS ARE SUPPLIED WITH CARD. FINAL LOCATION TO BE DETERMINED BY SYSTEM ENGINEER.

CARD POS 07
 LOGIC TYPE INFT

LOGIC Dwg. NO	REV	CODE IDENT NO	DRAWING NUMBER
39841400	1	09132	39904700
SHEET 2 OF 2			SHEET 15 OF

NOTES: UNLESS OTHERWISE SPECIFIED



Figure 5.9. CIE Control Logic Package



+

4 3 2 1

REV	ECO	DESCRIPTION	DATE	CHK	APPD
01		PREP. RE.	11-21-72	AA	AA
A	DDC	ECR 4110	10-31-72	AS	AS
B	13169	REVISED SH 1 & 2 PER ECO	11-14-72	AA	AA
C	13176	CHG'D JHT 5 PER ECO	11-21-72	AA	AA
D	13321	CHG'D SH 7 PER ECO	11-21-72	AA	AA

REFERENCE DRAWINGS		CONTROL DATA		TITLE	
3989900 - TOP ASSY		ANALOG-DIGITAL SYSTEMS DIVISION 14000 CALIF 92033		LOGIC DIAGRAM - COMPUTER INTERFACE EXPANDER	
COMPONENTS, EXCEPT AS NOTED		ELI02-A		CODE IDENT NO	
TOLERANCE	VALUE	RATING	DESIGN	C	09132
MIS. CAP.			CHK	DRAWING NUMBER	
			ENGR	39937400	
			MIC	SHEET 1 OF 7	
			APPD		

2. "D/C BUS" IS THE BACKPLANE PC CLAD DATA CONTROL BUS FOR POSITIONS 6 THRU 39.

1. FOR KEY TO SYMBOLS MANUAL SEE 39909515.

NOTES: UNLESS OTHERWISE SPECIFIED

39937400 B

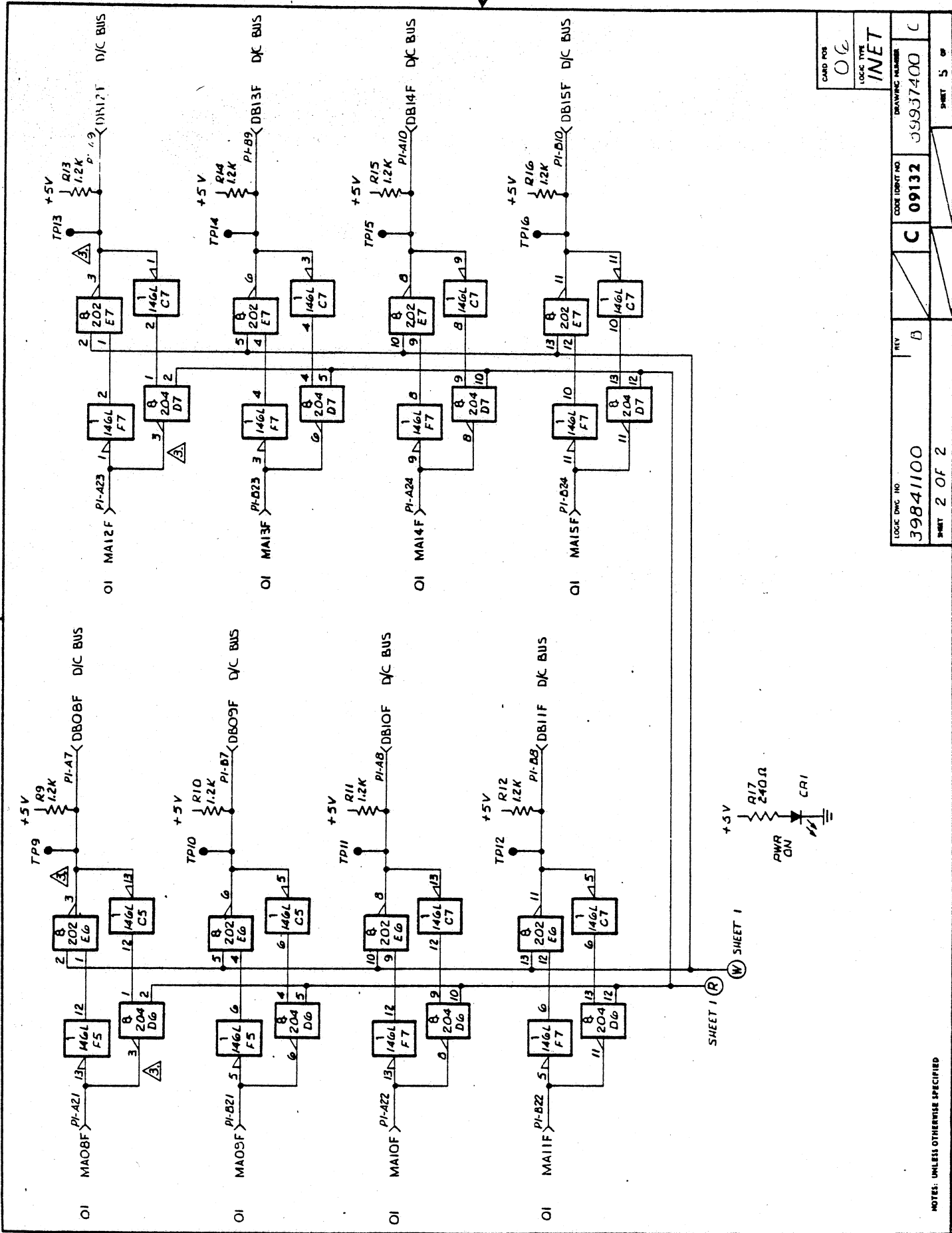

CARD NO. 06
 LOGIC TYPE INET

LOGIC Dwg. NO.	REV	CODE IDENT. NO.	DRAWING NUMBER	SHEET 5 OF
39841100	D	C 09132	05937400	C
SHEET 2 OF 2				

NOTES: UNLESS OTHERWISE SPECIFIED

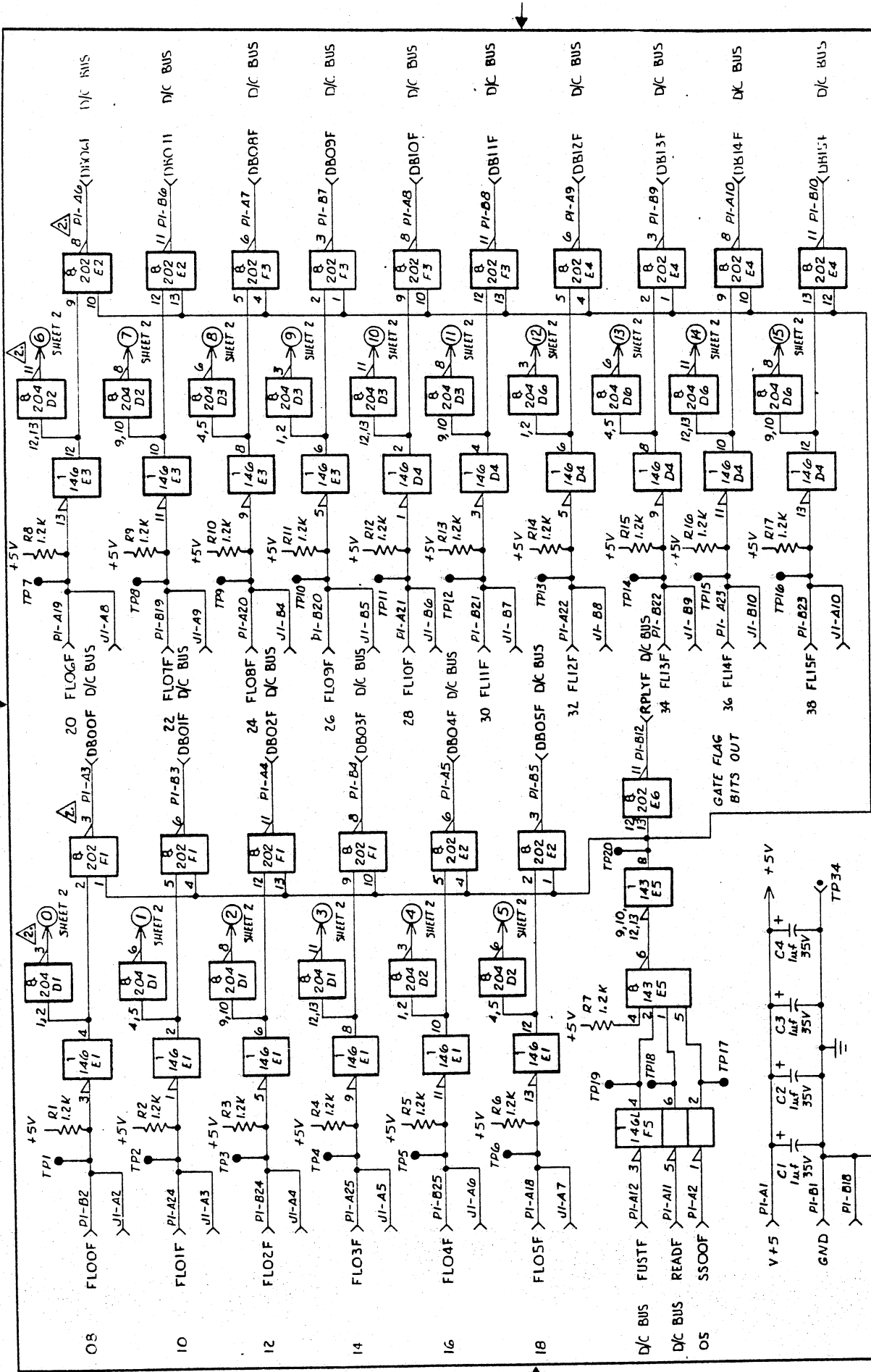

CONTROL DATA							ANALOG - DIGITAL SYSTEMS DIVISION (1000 CHIL 7001)						
DESIGN	CHK	ENGR	MIC	APPD	DATE	REV	DESIGN	CHK	ENGR	MIC	APPD	DATE	REV
EJ31AE10CA					6-20-72	A	EJ31AE10CA					6-20-72	
LOGIC TITLE INTERRUPT & FLAG STATUS							LOGIC TITLE INTERRUPT / FLAG STATUS						
LOGIC PNC NO 39841400							LOGIC PNC NO 39841400						
PWA NO 39841300							PWA NO 39841200						
SHEET NO 1 OF 2							SHEET NO 39841400						
DRAWING NUMBER 09132							DRAWING NUMBER 39841400						
CODE IDENT NO C							CODE IDENT NO C						
LOGIC TYPE INFT							LOGIC TYPE INFT						
CARD NOS 01							CARD NOS 01						

ALL ELEMENT IDENTIFIERS
 202 & 204 ARE OPEN
 COLLECTORS.
 ALL RESISTORS ARE 1/4 W.
 NOTES: UNLESS OTHERWISE SPECIFIED

DR 39841400

DETACHED LIST						
A	B	C	D	E	F	
1	7438	7404	7403	7403	7403	
2	7438	7404	7403	7403	7403	
3	7438	7404	7403	7403	7403	
4	7404	7403	7403	7403	7403	
5	7440	7403	7403	7403	7403	
6	7438	7403	7403	7403	7403	
7						

INTERRUPT LINES

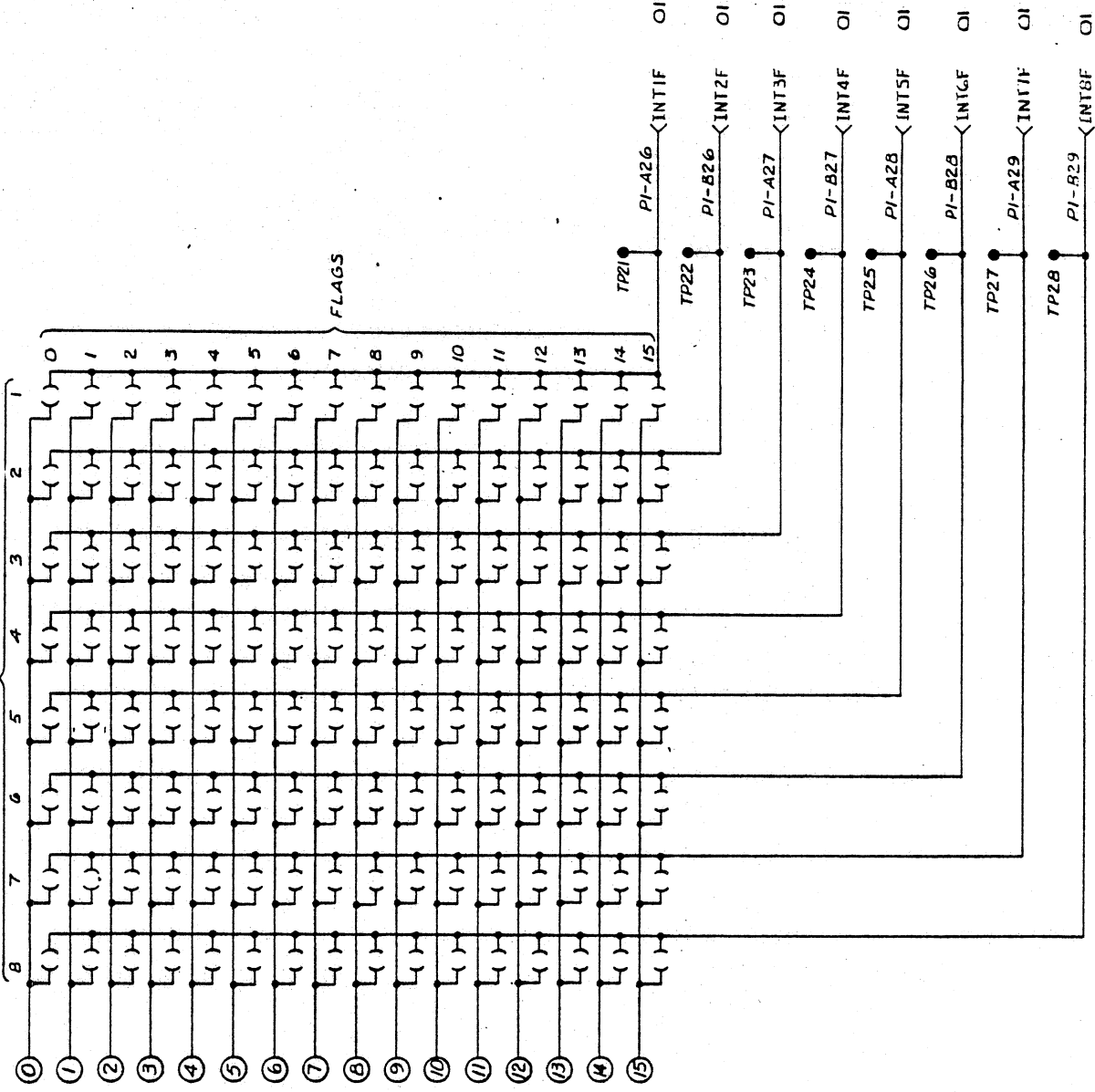

BOLTS & NUTS ARE SUPPLIED WITH CARD. FINAL LOCATION TO BE DETERMINED BY SYSTEM ENGINEER.

CARD NO.	07
LOGIC TYPE	INFT
LOGIC Dwg. NO.	3984/400
REV.	B
CODE IDENT. NO.	C 09132
DRAWING NUMBER	3984/400
SHEET	2 OF 2
SHEET	7 OF

NOTES: UNLESS OTHERWISE SPECIFIED

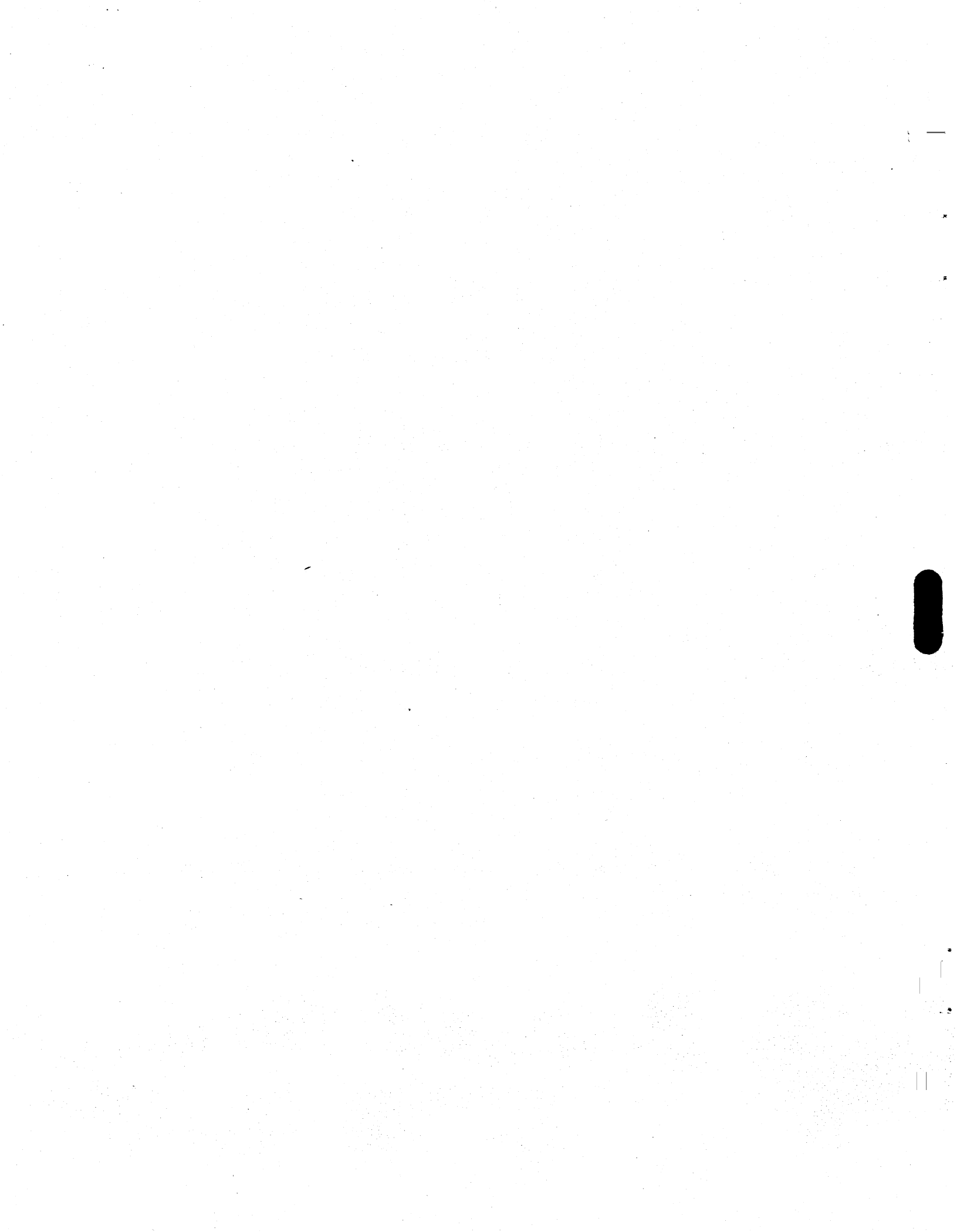

Section Six
MAINTENANCE

6.1 PREVENTIVE MAINTENANCE

Table 6.1 specifies the preventive maintenance (PM) to be performed on the CIU/CIE modules. Maintenance can be performed with either the SMM17 diagnostic or simple hand routines that perform input and/or output operations using the appropriate equipment number of the system configuration. The SMM17 diagnostic is Test No. 90 (refer to the SMM17 Reference Manual).

6.2 CALIBRATION AND ALIGNMENT

No calibration or alignment is required.

6.3 TROUBLESHOOTING

Troubleshooting can be performed on the CIU/CIE by using the SMM17 diagnostic, Test No. 90, Sections 0 through 6. Refer to the SMM17 Reference Manual for the use and description of the diagnostic. This diagnostic will locate the fault to a board level. The diagnostic exercises equipment connect decode, module select, station device select, loading data/control bus lines, and flag status/interrupt response. Error printouts are provided specifying the instruction performed, expected and actual results, and the condition causing the error.

The following groups of cards are interchangeable for troubleshooting:

- A-line transmitter/receiver cards (positions 3 and 4) in the CIU module.
- Address control card (position 5) of the CIU and CIE modules. (Module select jumper requires changing to appropriate position).

- Data bus driver/receiver card (position 6) of CIU and CIE modules.
- Interrupt/flag status card (position 7) of CIU and CIE modules. (Interrupt jumpers may require changing to appropriate positions for correct interrupt response.)

Table 6.1. Preventive Maintenance Index (PMI)

LEVEL 1-----Quarterly

LEVEL 2-----Annually

ESTIMATED TIME (MINUTES)	LEVEL	ITEM	PREVENTIVE MAINTENANCE
3	1	6.3.1	Check filters
5	1	6.3.2	Check power supplies
40	2	6.3.3	Run diagnostic with margins

This PMI is the recommended frequency of performing preventive maintenance on this equipment. Scheduling of this preventive maintenance is a site responsibility. Scheduling may include variations in the recommended frequency due to individual site requirements (i.e., usage, environment, time, etc.).

6.3.1 CHECK FILTERS

CHECK/Conditions

Action

1. Remove blower filter and inspect for flow restriction caused by dirt or objects.

CHECK: Is filter clean?

YES



Next Item

NO

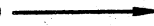

1. Vacuum clean the filter.
2. If it does not come clean with vacuuming, wash in mild detergent.
3. If it is still too dirty, replace the filter with a new one.

6.3.2 CHECK POWER SUPPLIES

CHECK/Conditions

Action

1. Measure the supplies for their nominal ± 5 vdc outputs. Verify the ripple is within 30 millivolts rms or 84 millivolts pp. Keep a record, and note any history towards a degradation.

CHECK: Power supplies acceptable?

YES



Next Item

NO



1. Check for blown fuses, circuit shorts, open diodes, improper input voltages, grounding, etc. Repair or replace any defective components.

6.3.3 RUN DIAGNOSTIC WITH MARGINS

CHECK/Conditions

Action

1. Prepare the system to run SMM17 Test 90, Sections 9, 10, and 11 of the SMM17 Reference Manual. The system will need one word of digital output and one word of digital input to complete these sections. The boards may be plugged into the same slot, or cabled

together via the I/O connectors.
If the system does not have both digital input and output boards, it is recommended that one of each be ordered as test equipment for this module.

2. Run F passes of test 90. There should be no errors.

CHECK: Any diagnostic errors?

NO



Next Item

YES → 1. Repair or replace faulty component or assembly.

NOTE: The digital input/output boards are assumed to be good. You should be verifying that the interface is good.

6.4

MAINTENANCE AIDS

Use the following as maintenance aids:

- Card extender, 9-inch logic type, 2NMT Card No. 39844100.
- Standard module pin and chip locations are shown in Figure 6.1.
- 7400 Series transistor-transistor logic (TTL) element pin orientation is shown in Figure 6.2.
- Integrated circuit logic symbols are shown in the Key to Logic Symbols Manual.

NOTE: It is assumed the digital input/output boards are good. Keep in mind that you are verifying the interface operations.

3. Repeat preceding step 2 at $\pm 5\%$ voltage margins. Care should be exercised while adjusting power supplies, as TTL is sensitive to over-voltages.

CHECK: Any errors?

NO

YES \longrightarrow 1. Repair or replace failing part or assembly.

- \downarrow
4. Return power supply levels to their nominal values. Run sections 9, 10, and 11 again while lightly shock testing. Caution should be exercised not to generate problems or to disturb connector-connector contacts while shocking. Then run section 6 to check the interrupt and status circuitry.

CHECK: Any failures?

NO

YES \longrightarrow 1. Repair or replace the sensitive parts.

\downarrow
End Preventive Maintenance Program

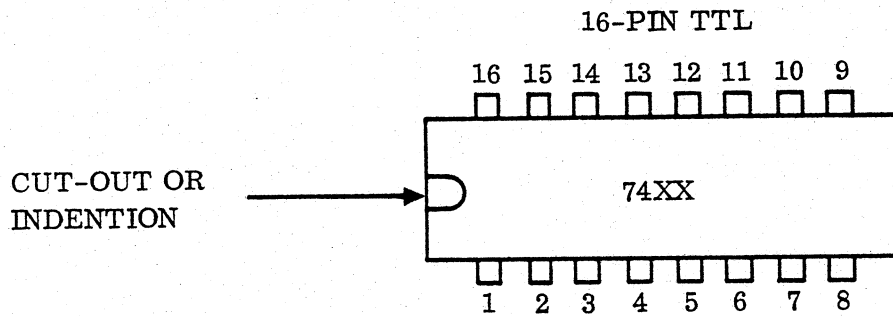
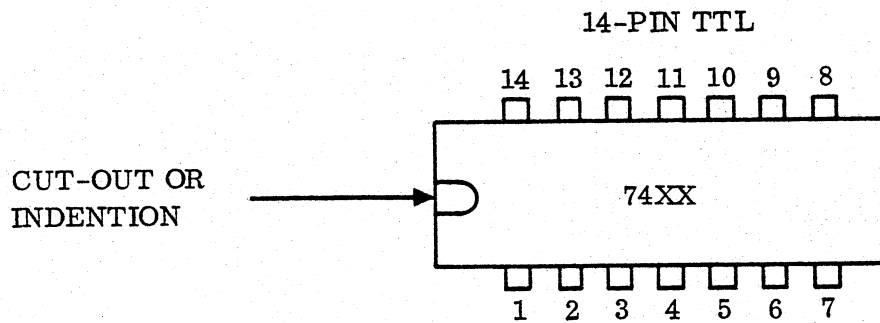

Figure 6.2. Pin Configuration, Top View

Section Seven
PARTS DATA

7.1 PARTS DATA

This section contains the parts lists for the CIU/CIE. Table 7.1 is a list of each printed wiring assembly (PWA), a description of it, and the part number. Figures 7.1 through 7.5 contain the PWA drawings and parts list for each card. Table 7.2 is a list of miscellaneous parts data including part numbers and descriptions.

Table 7.1. CIU/CIE Control Card List

PART NO.	DESCRIPTION	TYPE	USED IN
39840100	PWA-Q-Line Receiver and Decode	1NBT	CIU only
39840400	PWA-A-Line Transmitter/Receiver	1NCT	CIU only
39840700	PWA-Address Control	1NDT	CIU and CIE
39841000	PWA-Data Bus Driver/Receiver	1NET	CIU and CIE
39841300	PWA-Interrupt/Flag Status	1NFT	CIU and CIE

Table 7.2. Miscellaneous Parts List

PART NO.	DESCRIPTION	USED WITH
39514900	Blower Assembly (Contains 2 Axial Fans)	CIU and CIE
24536500	Axial Fan, 270 CFM	Blower Assy
39670401	Power Supply, -5 V dc	CIU and CIE
39670403	Power Supply, +5 V dc	CIU and CIE

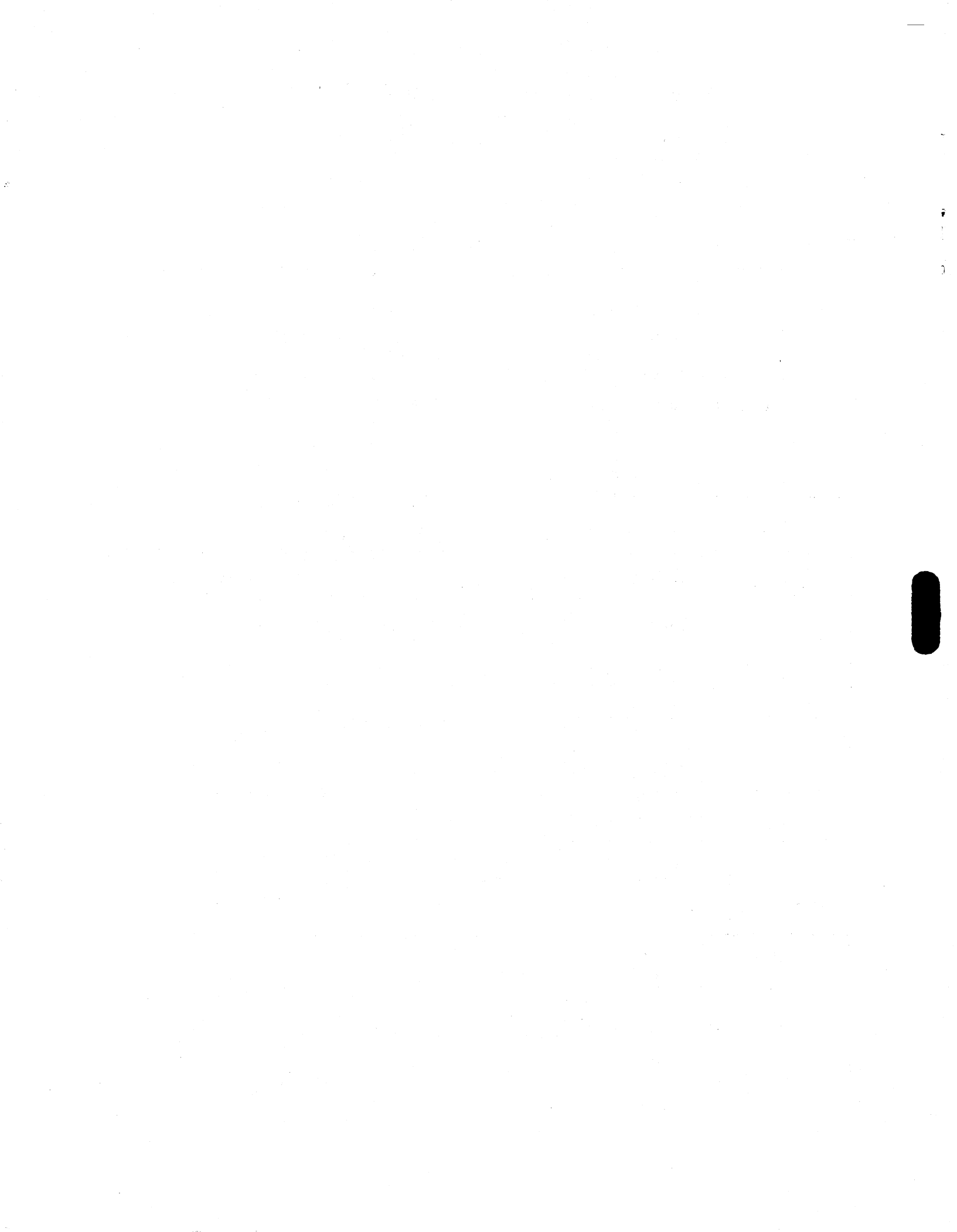
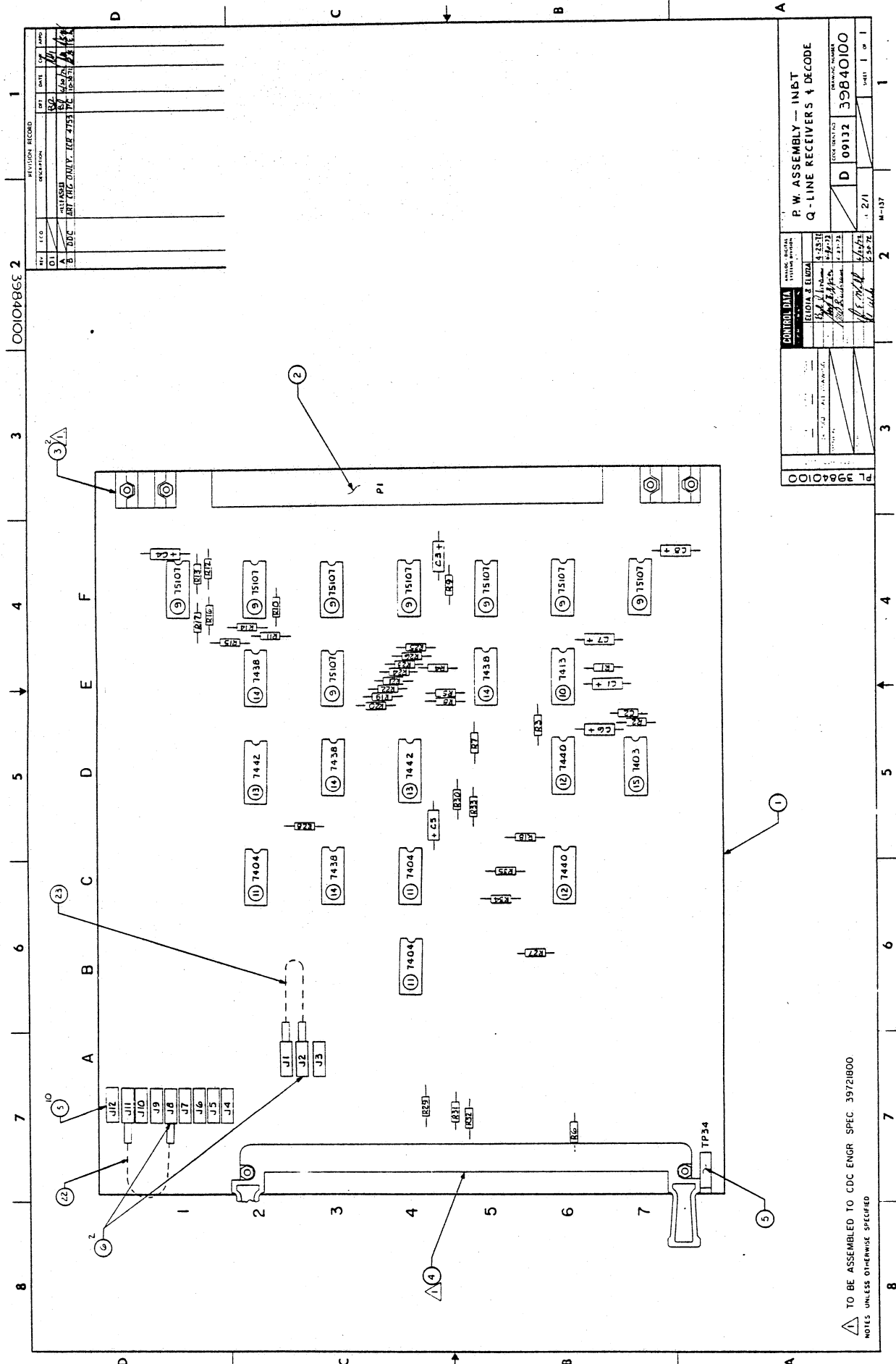

Figure 7.1. Q-Line Receiver and Decode (1NBT)





REVISION RECORD			
REV.	DATE	BY	APP.
1	10/15/64	W.A.	
2	11/16/64	W.A.	
3	12/17/64	W.A.	
4	1/14/65	W.A.	
5	2/11/65	W.A.	
6	3/11/65	W.A.	
7	4/14/65	W.A.	
8	5/11/65	W.A.	
9	6/11/65	W.A.	
10	7/11/65	W.A.	
11	8/11/65	W.A.	
12	9/11/65	W.A.	
13	10/11/65	W.A.	
14	11/11/65	W.A.	
15	12/11/65	W.A.	

CONTROL DATA		P.W. ASSEMBLY - INBT	
TITLE: Q-LINE RECEIVERS & DECODE		DRAWING NUMBER: 39840100	
DATE: 11/16/64		REV: 1 OF 1	
DRAWN: W.A.		CHECKED: W.A.	
APPROVED: W.A.		DATE: 11/16/64	
SCALE: 1:1		MATERIAL: 39840100	

▲ TO BE ASSEMBLED TO CDC ENGR SPEC 39721800
 NOTES UNLESS OTHERWISE SPECIFIED

CONTROL DATA CORPORATION

ANALOG - DIGITAL SYSTEMS DIVISION
La Jolla, Calif. 92037

CODE IDENT
09132

SHEET **2**

DOCUMENT NO
39840100

REV.
A

FIND NO	PART IDENTIFICATION	QUANTITY REQUIRED										UNIT OF MEAS	NOMENCLATURE OR DESCRIPTION	SPECIFICATIONS, NOTES, OR MATERIAL	
		00													
1	39840000	1												PW BOARD	
2	94243400	1												CONNECTOR	62 CONTACT PI
3	39827500	2												GUIDE, APPROACH	
4	52936000	1												AIR SEAL/CARD EXTRACTOR	
5	38958509	10												TEST JACK (PURPLE)	J1, J3-J7, J9-J12
6	38958507	2												TEST JACK (YELLOW)	J2, J8
7	38958502	1												TEST JACK (BLACK)	TP34
8	24505229	7												CAP TANT 1uf 35V 10%	C1, C3-C8
9	50252900	8												INT CKT (75107A)	
10	39389900	1												(7413)	
11	39389700	3												(7404)	
12	39389200	2												(7440)	
13	39385800	2												(7442)	
14	62031200	4												INT CKT (7438)	
15	15104200	1												INT CKT (7403)	
16	24500063	1												RES COMP 1K 1/4W 5%	R9
17	24500070	2												RES COMP 2K 1/4W 5%	R1, R2
18	24500047	16												RES COMP 220Ω 1/4W 5%	R3, R4, R5, R10-R13 R18-R26
19	84996725	1												CAP CER 680pf 100V 10%	C2

Figure 7.2. A-Line Transmitter/Receiver (1NCT)



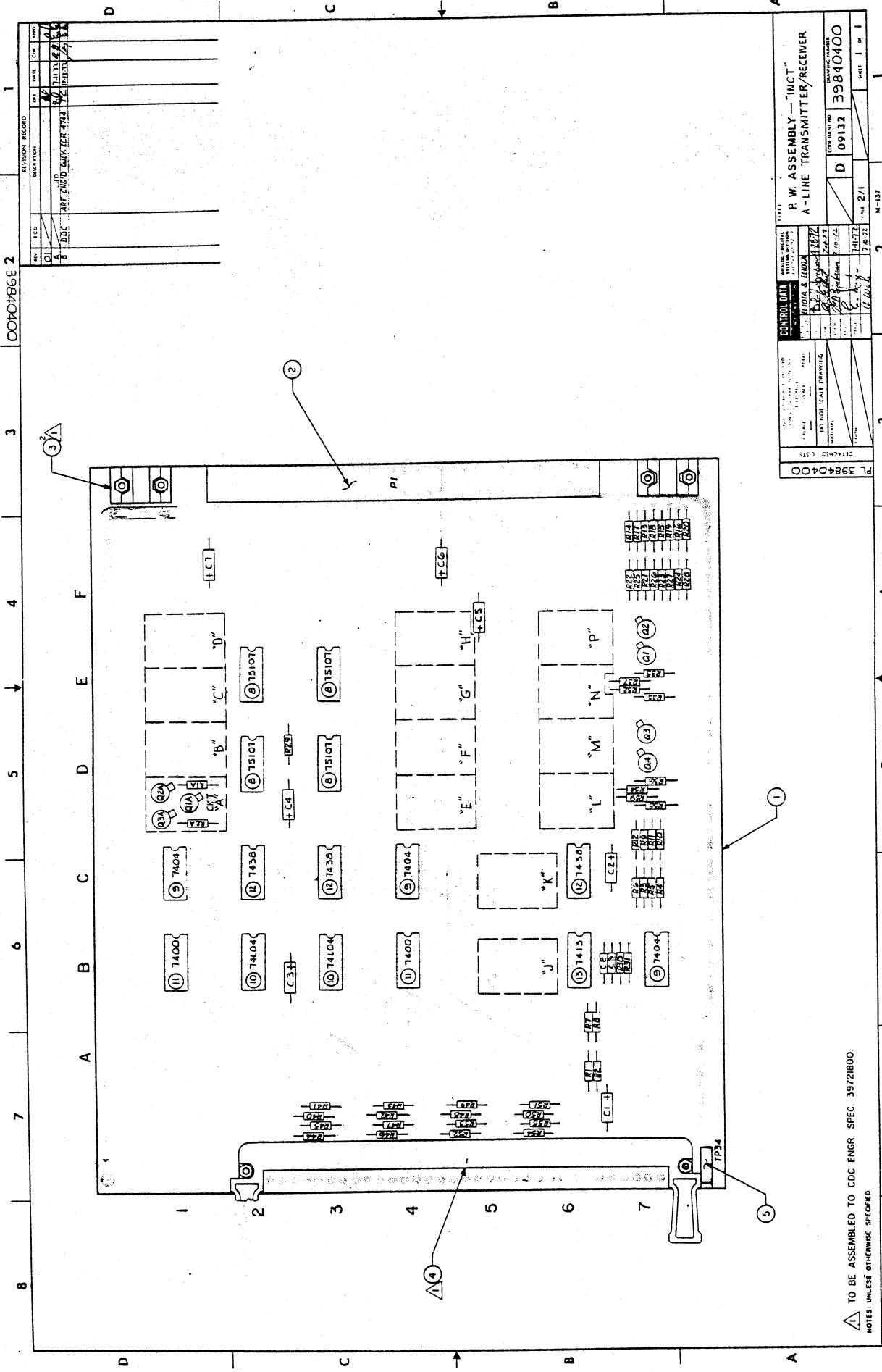

CONTROL DATA DRAWING NO. 39840400 REV. 1 DATE 11/15/72 DESIGNED BY [Signature] CHECKED BY [Signature] APPROVED BY [Signature]		PART 2/1 M-137	
REVISION RECORD		FL 39840400	
REV.	ECO	DATE	DESCRIPTION
1	A	11/15/72	INITIAL
2	B	11/15/72	INITIAL
3	C	11/15/72	INITIAL
4	D	11/15/72	INITIAL
5	E	11/15/72	INITIAL
6	F	11/15/72	INITIAL
7	G	11/15/72	INITIAL
8	H	11/15/72	INITIAL
9	I	11/15/72	INITIAL
10	J	11/15/72	INITIAL
11	K	11/15/72	INITIAL
12	L	11/15/72	INITIAL
13	M	11/15/72	INITIAL
14	N	11/15/72	INITIAL
15	O	11/15/72	INITIAL
16	P	11/15/72	INITIAL

TO BE ASSEMBLED TO CDC ENGR. SPEC. 39721800.
 NOTES: UNLESS OTHERWISE SPECIFIED

CONTROL DATA CORPORATION

ANALOG - DIGITAL SYSTEMS DIVISION
La Jolla, Calif. 92037

CODE IDENT
09132

SHEET **2**

PL

DOCUMENT NO

39840400

REV

A

FIND NO	PART IDENTIFICATION	QUANTITY REQUIRED								UNIT OF MEAS	NOMENCLATURE OR DESCRIPTION	SPECIFICATIONS, NOTES, OR MATERIAL
1	39840300	1									P W BOARD	
2	94243400	1									CONNECTOR	PI
3	39827500	2									GUIDE APPROACH	
4	52936000	1									AIR SEAL	(CARD EXTRACTOR)
5	38958502	1									TEST JACK (BLACK)	TP34
6	24505229	7									CAP, TANT, 1M, 35V, 10%	C1-C7
7	39840500	REF									LOGIC DIAG	
8	50252900	4									INT CKT	75107
9	39389700	3										7404
10	15112700	2										74L04
11	39388300	2										7400
12	62031200	3										7438
13	39389900	1									INT CKT	7413
14	24562100	16									TRANSISTOR	Q1,Q2, Q3A-Q3P
15	24562300	30									TRANSISTOR	Q3,Q4, Q1A-Q2P
16	84996729	2									CAP, CER, 1000Pf, 100V	C8,C9
17	24500033	8									RES, COMP, 56- Ω , 1/4W, 5%	R21-R28
18	24500034	2										62- Ω
19	24500044	30										160- Ω
20	24500050	2									RES, COMP, 300- Ω , 1/4W, 5%	R35, R36 R33, R38, R1A-R2P R32, R39

Figure 7.3. Address Control (1NDT)



39840100 2 3 4 5 6 7 8

REV	ECO	DESCRIPTION	DATE	BY	CHK	APP
1		ISSUED	1/27/54			
2		REVISION RECORD				
3		REVISION RECORD				
4		REVISION RECORD				
5		REVISION RECORD				
6		REVISION RECORD				
7		REVISION RECORD				
8		REVISION RECORD				

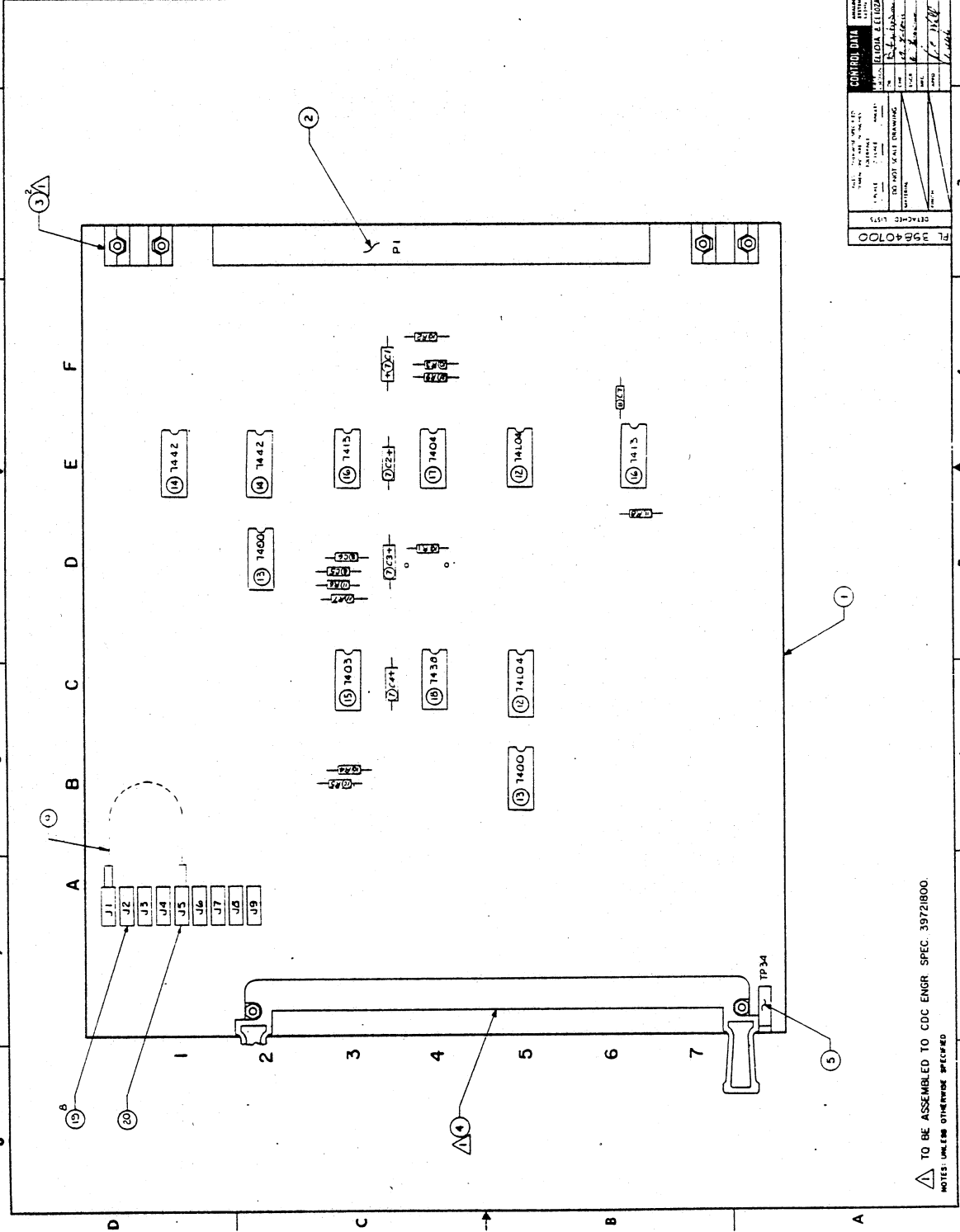

CONTROL UNIT		DRAWING		REVISION RECORD	
REV	ECO	DATE	BY	CHK	APP
1		1/27/54			
2		1/27/54			
3		1/27/54			
4		1/27/54			
5		1/27/54			
6		1/27/54			
7		1/27/54			
8		1/27/54			

TITLE: P. W. ASSEMBLY - INDJ ADDRESS CONTROL
 DRAWING NO: 09132
 SHEET: 1 OF 1
 M-137
 39840100

TO BE ASSEMBLED TO CDC ENGR SPEC. 3971800.
 NOTES: UNLESS OTHERWISE SPECIFIED

4

DWN	<i>[Signature]</i>	12-1-71	CONTROL DATA	TITLE	P W ASSY - INDT ADDRESS CONTROL	PREFIX	DOCUMENT NO.	REV	E
CMND	<i>[Signature]</i>	6-2-72	ANALOG - DIGITAL SYSTEMS DIVISION La Jolla, Calif. 92037	FIRST USED ON	ELIOIA & ELIOZA	SHEET 1 OF 2	39840700		
ENG	<i>[Signature]</i>	5-20-72		CODE IDENT					
MFG	<i>[Signature]</i>	4-30-72							
APPR	<i>[Signature]</i>	6-30-72							

SHEET REVISION STATUS				REVISION RECORD			
REV	ECO	DESCRIPTION	DRFT	DATE	APP		
DI			G.C.				
A		RELEASED	G.C.	6/30/72			
C	13231	AUTOMATED P/L	LVP	5-15-72			
E	13412	ADDED FN 21.	TC	1-24-73			

NOTES:

DETACHED LISTS

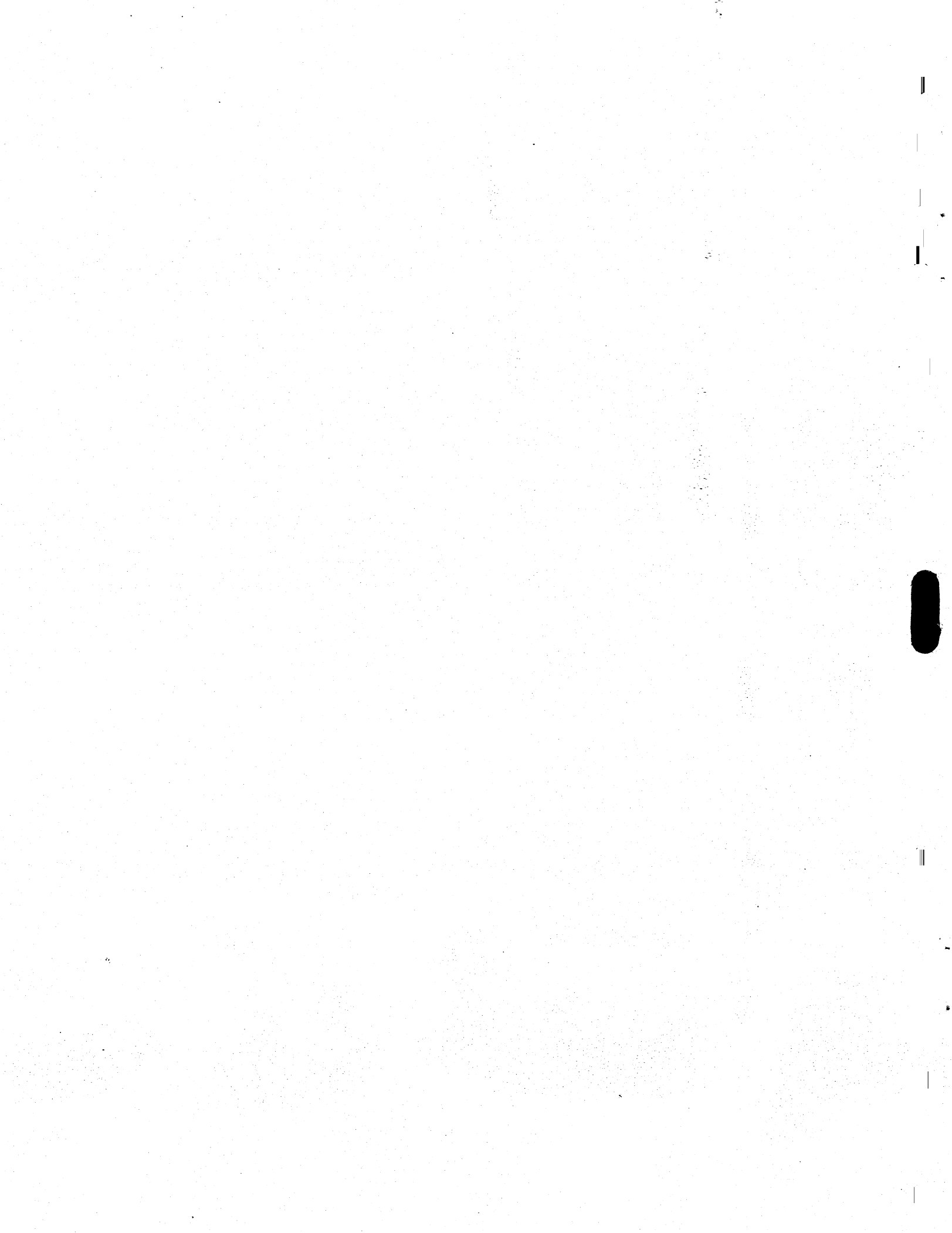

Figure 7.4. Data Bus Driver/Receiver (1NET)

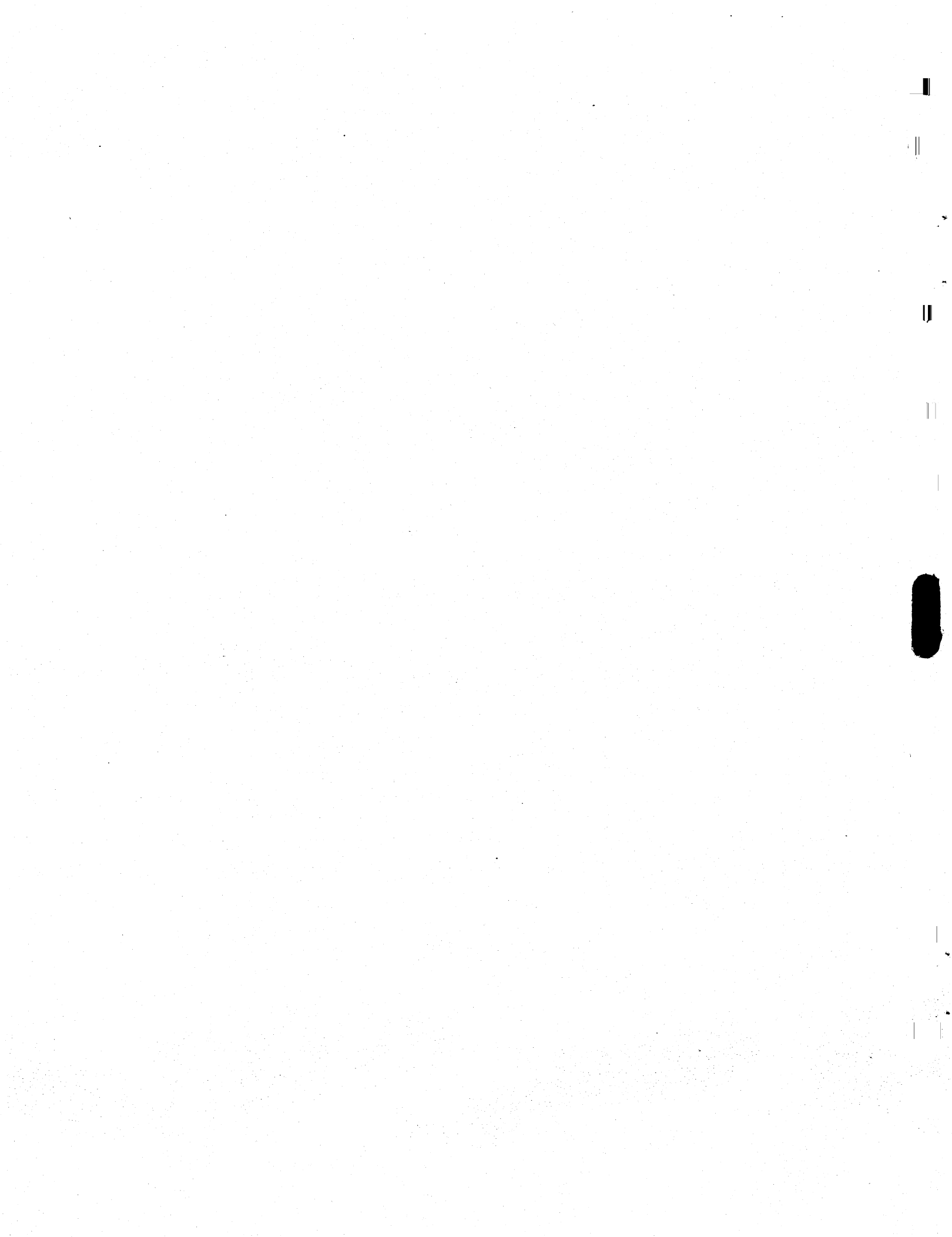
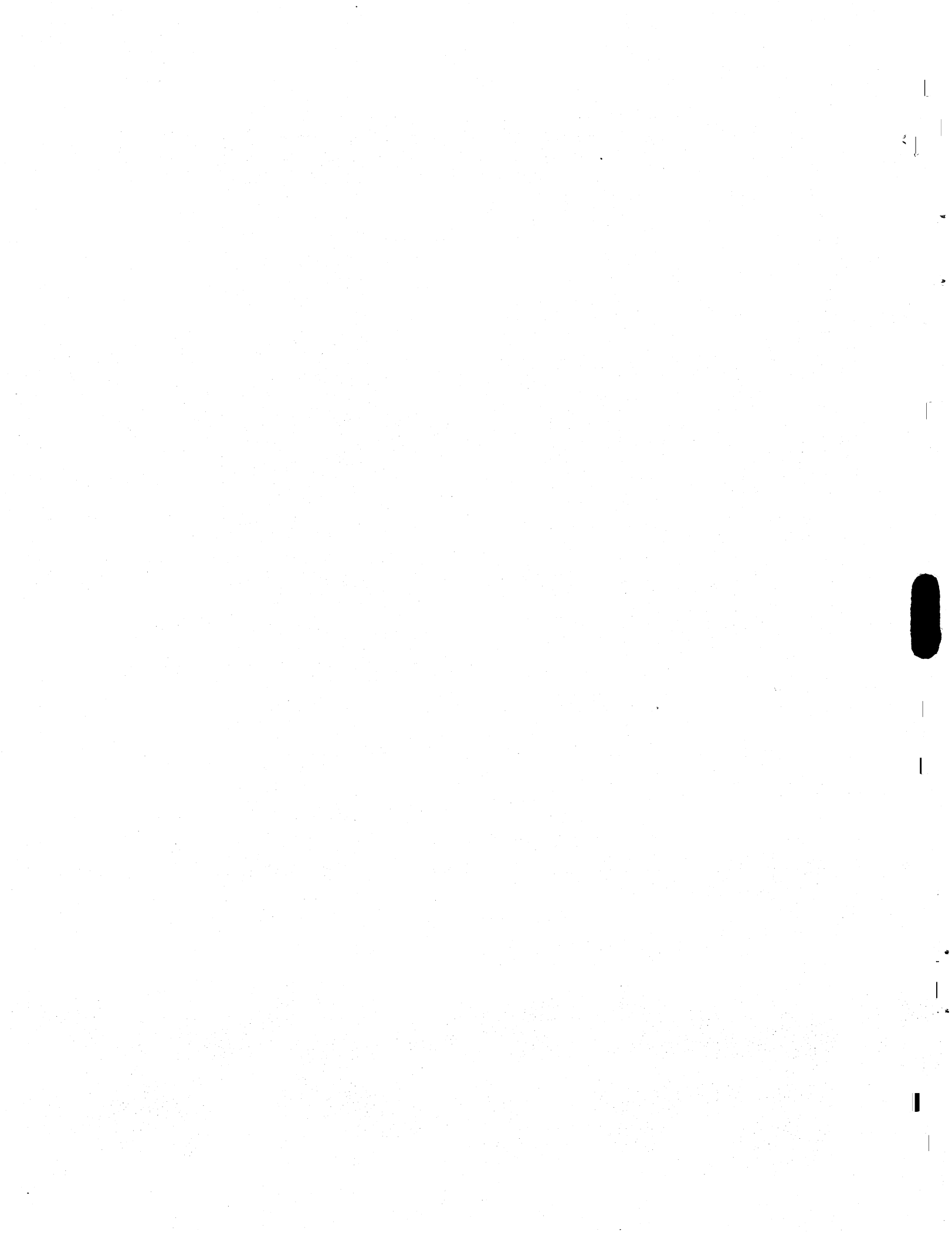



Figure 7.5. Interrupt and Flag Status (INFT)



CONTROL DATA CORPORATION

ANALOG - DIGITAL SYSTEMS DIVISION
La Jolla, Calif. 92037

CODE IDENT
09132

SHEET **2**

PL

DOCUMENT NO

39841300

REV.

A

FIND NO	PART IDENTIFICATION	QUANTITY REQUIRED										UNIT OF MEAS	NOMENCLATURE OR DESCRIPTION	SPECIFICATIONS, NOTES, OR MATERIAL	
		00													
1	39841200	1												PW BOARD	
2	94243400	1												CONNECTOR	62 CONTACTS, PI
3	39827500	2												GUIDE, APPROACH	
4	52936000	1												AIR SEAL	(CARD EXTRACTOR)
5	38958502	1												TEST JACK	BLACK TP34
6	24505229	4												CAP, TANT, 1uf, 35V, 10% CI - C4	
7	39841400	REF												LOGIC DIAGRAM	
8	39903604	1												CONNECTOR, RECPT	20 PINS JI
9	24500065	17												RES COMP 1.2K 1/4W 5% RI - R17	
10															
11	15104200	5												INT CKT (7403)	
12	39389200	1												(7440)	
13	15112700	1												(74L04)	
14	39389700	3												(7404)	
15	62031200	4												INT CKT (7438)	
16															
17	39908200	16												SCREW, PAN HD, PHL	4-40 x 1/4 NICKEL PLATED
18	39908300	16												NUT 5M. PATTERN	4-40 NICKEL PLATED
19	39908400	16												WASHER SPG LOCK	4 NICKEL PLATED
20															

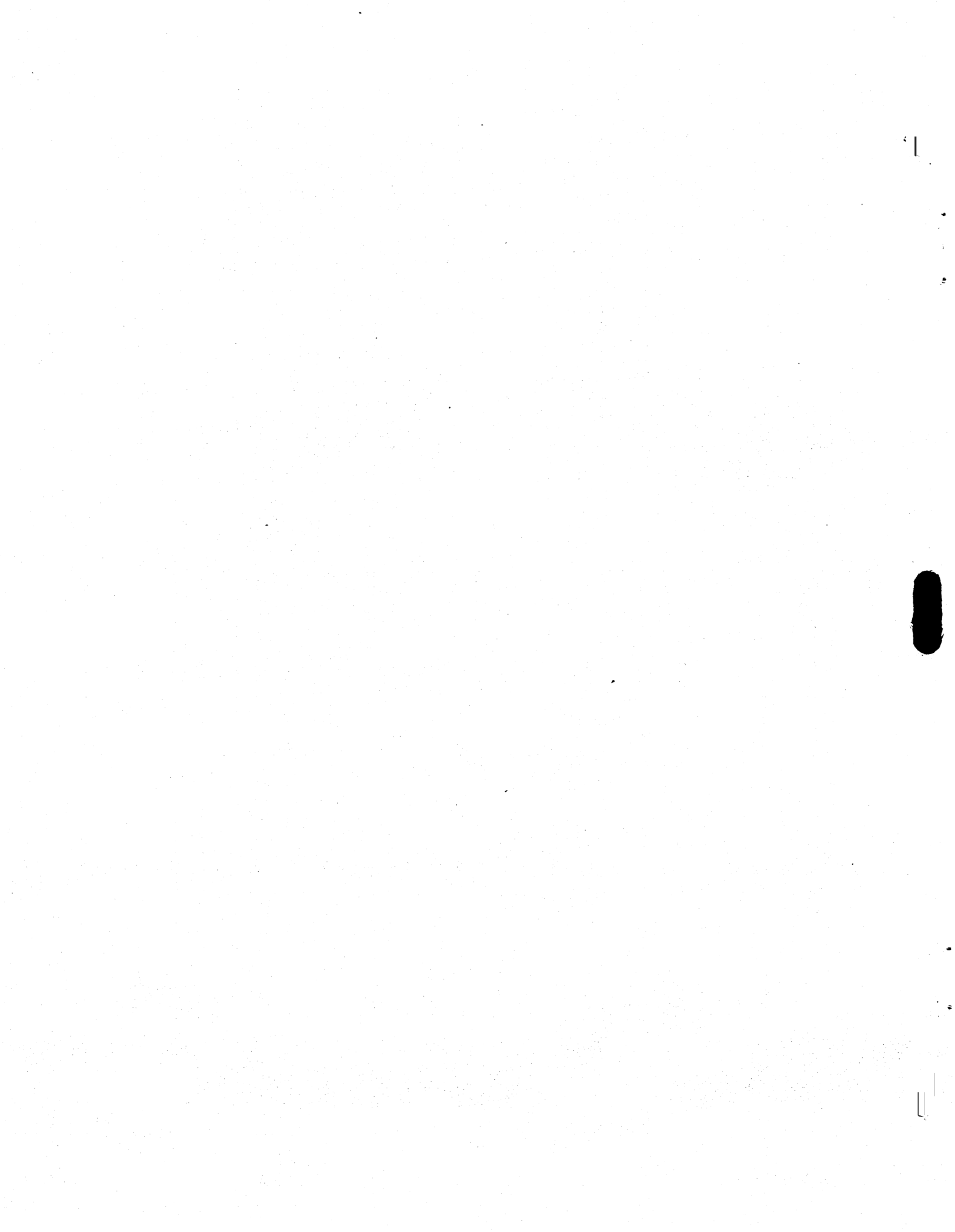

Section Eight

WIRE LIST

8.1 WIRE LIST

This section contains a complete wire list for the CIU/CIE. Figure 8.1 is the backplane wire list for the CIU module, Figure 8.2 is the backplane wire list for the CIE module, and Figure 8.3 is the chassis wire list for the CIU module.

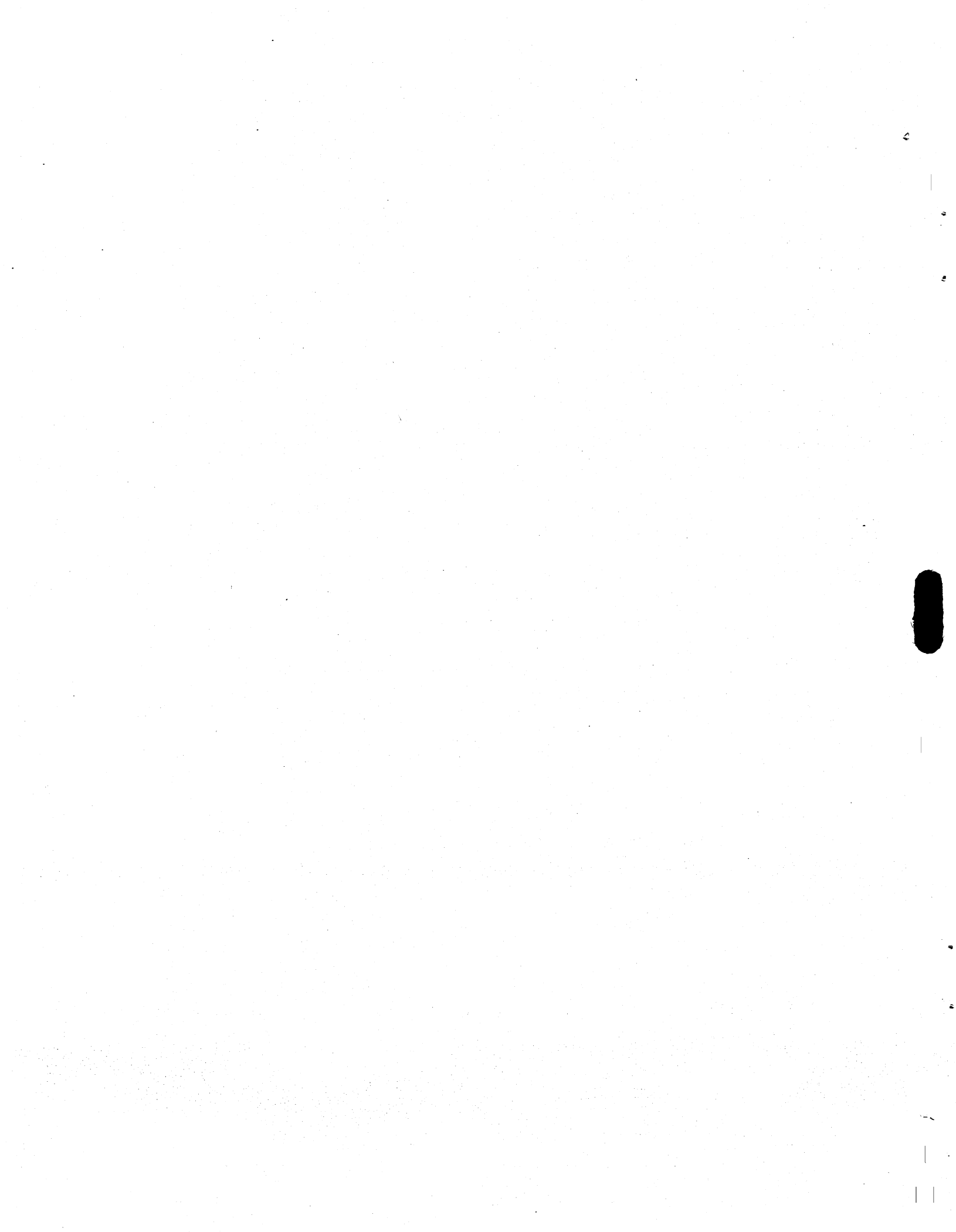
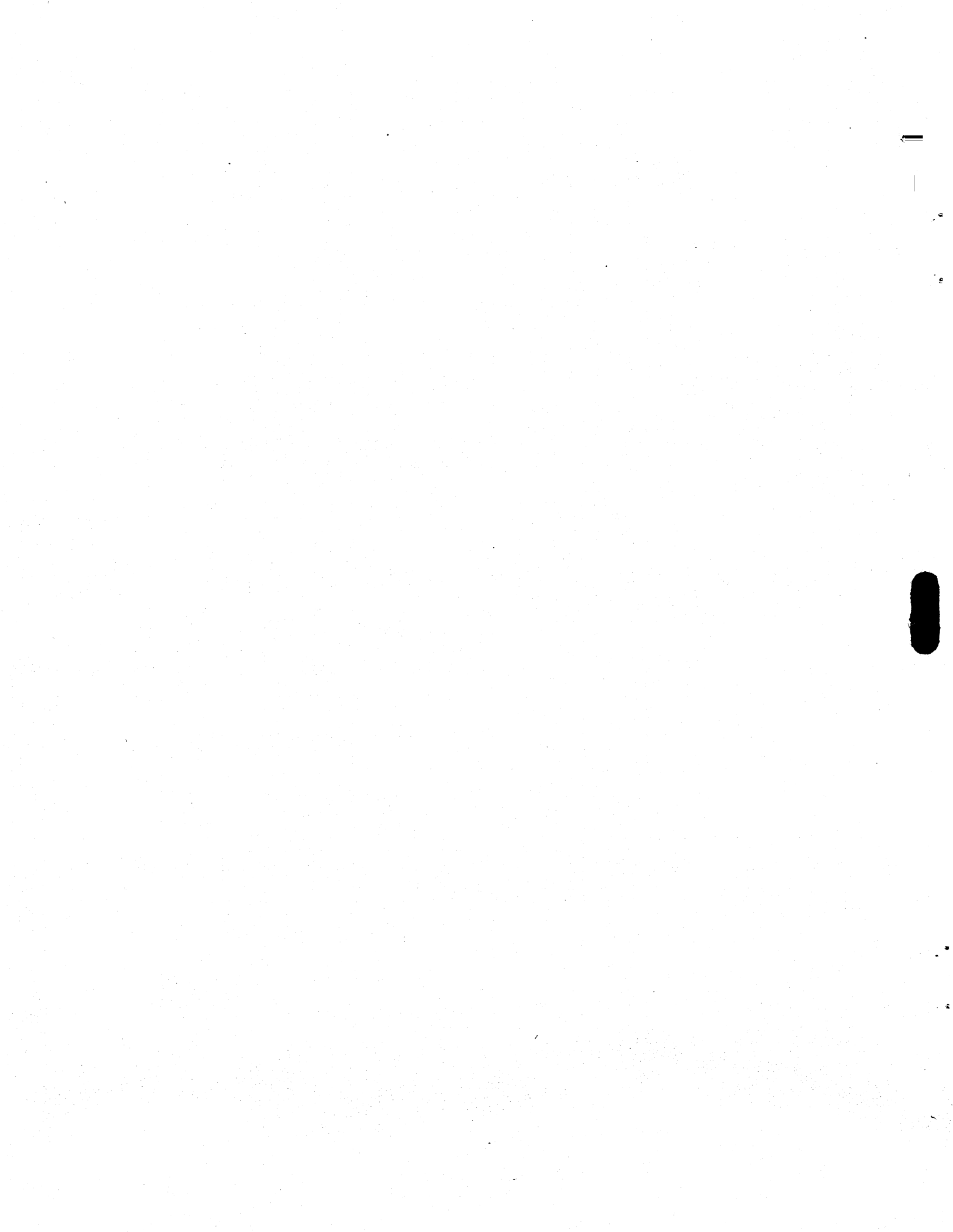

Figure 8.1. Backplane Wire List - CIU Module -



REVISION RECORD

REV	CO	DESCRIPTION	DRFT	DATE	CHKD	APP
		FOR REV SEE SHEET NO. 12.				

NOTES :

- I. IDENTIFY WITH PN & REV LTR BY MEANS OF TAG, LABEL OR SIMILAR METHOD.

DWN	<i>B. Johnson</i>	5-5-72	CONTROL DATA	LA JOLLA SYSTEMS DIVISION La Jolla, Calif. 92037	TITLE	BACK PLANE ASSY (COMPUTER INTERFACE UNIT)
CHKD	<i>P. Bellert</i>	5-11-72			CODE IDENT	09132
ENG	<i>G.H. Drake</i>	10-25-72	SCALE		39874500	SHEET 1 OF 12
MFG	<i>E. Acuna</i>	10-30-72				
APP						

CONTROL DATA

DOCUMENT NO. **39895500** REV. **A**

CONDUCTOR IDENT	FIND NO	GAUGE (REF)	COLOR (REF)	LENGTH (APPROX)	ORIGIN		ACCESS FIND NO	DESTINATION		ACCESS FIND NO	REMARKS
1	3	30	YEL		O7	A24		10	B2		FLO1F
2	▲	▲	▲		▲	B24		12	▲		FLO2F
3						A25		14			FLO3F
4						B25		16			FLO4F
5						A18		18			FLO5F
6						A19		20			FLO6F
7						B19		22			FLO7F
8						A20		24			FLO8F
9						B20		26			FLO9F
10						A21		28			FLI0F
11						B21		30			FLI1F
12						A22		32			FLI2F
13						B22		34			FLI3F
14	▼	▼	▼		▼	A23		36	▼		FLI4F
15	3	30	YEL		O7	B23		38	B2		FLI5F
16											
17											
18											
19											
20											

CONTROL DATA

CODE IDENT

SHEET

4

WL

DOCUMENT NO.

39895500

REV.

A

CONDUCTOR IDENT	FIND NO	GAUGE (REF.)	COLOR (REF.)	LENGTH (APPROX)	ORIGIN		ACCESS FIND NO.	DESTINATION		ACCESS FIND NO.	REMARKS
21	3	30	YEL		05	A28		06	A28		CNRDF
22	↑	↑	↑		05	B28		06	B28		CNWTF
23					01	A14		05	A14		ISY1F
24					01	B14		05	B14		ISY2F
25					01	A26		04	A21		INT1F
26					04	A21		07	A26		INT1F
27					01	B26		04	B21		INT2F
28					04	B21		07	B26		INT2F
29					01	A27		04	A24		INT3F
30					04	A24		07	A27		INT3F
31					01	B27		04	B24		INT4F
32					04	B24		07	B27		INT4F
33					01	A28		03	A21		INT5F
34					03	A21		07	A28		INT5F
35	↓	↓	↓		01	B28		03	B21		INT6F
36	3	30	YEL		03	B21		07	B28		INT6F
37											
38											
39											
40											

PRINTED IN U.S.A.

CONTROL DATA

CODE IDENT

SHEET

5

WL

DOCUMENT NO.

39895500

REV.

A

CONDUCTOR IDENT	FIND NO	GAUGE (REF.)	COLOR (REF.)	LENGTH (APPROX)	ORIGIN		ACCESS FIND NO.	DESTINATION		ACCESS FIND NO.	REMARKS
41	3	30	YEL		01	A29		03	A24		INT7F
42	▲	▲	▲		03	A24		07	A29		INT7F
43					01	B29		03	B24		INT8F
44					03	B24		07	B29		INT8F
45					01	A3		03	A3		MAOOF
46					03	A3		06	A25		MAOOF
47					01	B3		03	B3		MAOIF
48					03	B3		06	B25		MAOIF
49					01	A4		03	A6		MAO2F
50					03	A6		06	A26		MAO2F
51					01	B4		03	B6		MAO3F
52					03	B6		06	B26		MAO3F
53					01	A5		03	A9		MAO4F
54					03	A9		06	A19		MAO4F
55	▼	▼	▼		01	B5		03	B9		MAO5F
56	3	30	YEL		03	B9		06	B19		MAO5F
57											
58											
59											
60											

CONDUCTOR IDENT	FIND NO.	GAUGE (REF.)	COLOR (REF.)	LENGTH (APPROX)	ORIGIN		ACCESS FIND NO.	DESTINATION		ACCESS FIND NO.	REMARKS
					O1	A6		O3	A12		
61	3	30	YEL		O1	A6		O3	A12		MAO6F
62					O3	A12		O6	A20		MAO6F
63					O1	B6		O3	B12		MAO7F
64					O3	B12		O6	B20		MAO7F
65					O1	A7		O4	A3		MAO8F
66					O4	A3		O6	A21		MAO8F
67					O1	B7		O4	B3		MAO9F
68					O4	B3		O6	B21		MAO9F
69					O1	A8		O4	A6		MAIOF
70					O4	A6		O6	A22		MAIOF
71					O1	B8		O4	B6		MAI1F
72					O4	B6		O6	B22		MAI1F
73					O1	A9		O4	A9		MAI2F
74					O4	A9		O6	A23		MAI2F
75					O1	B9		O4	B9		MAI3F
76	3	30	YEL		O4	B9		O6	B23		MAI3F
77											
78											
79											
80											

CONTROL DATA

CODE IDENT

SHEET 7

WL

DOCUMENT NO.

39895500

REV.

A

CONDUCTOR IDENT	FIND NO	GAUGE (REF)	COLOR (REF)	LENGTH (APPROX)	ORIGIN		ACCESS FIND NO.	DESTINATION		ACCESS FIND NO.	REMARKS
81	3	30	YEL		01	A10		04	A12		MA14F
82	↑	↑	↑		04	A12		06	A24		MA14F
83					01	B10		04	B12		MA15F
84					04	B12		06	B24		MA15F
85					01	A11		02	B22		MRDF
86					02	B22		05	A27		MRDF
87					01	A12		02	A24		MFSTF
88					02	A24		05	A22		MFSTF
89					01	A13		04	B27		MRJTF
90					04	B27		05	B29		MRJTF
91					01	A15		03	A27		MCINF
92					03	A27		05	B30		MCINF
93					01	B11		02	A22		MWTF
94					02	A22		05	B27		MWTF
95					01	B12		04	A27		MRPYF
96					04	A27		05	A29		MRPYF
97	↓	↓	↓		01	B13		02	B25		MMCLF
98	3	30	YEL		02	B25		05	B22		MMCLF
99											
100											

CONDUCTOR IDENT.	FIND NO.	GAUGE (REF.)	COLOR (REF.)	LENGTH (APPROX)	ORIGIN	ACCESS FIND NO.	DESTINATION	ACCESS FIND NO.	REMARKS
101	3	30	YEL		01 A16		02 A3		MQ00F
102	↑	↑	↑		02 A3		05 A20		MQ00F
103					01 B16		02 B3		MQ01F
104					02 B3		05 B20		MQ01F
105					01 A17		02 A6		MQ02F
106					02 A6		05 A21		MQ02F
107					01 B17		02 B6		MQ03F
108					02 B6		05 B21		MQ03F
109					01 A20		02 A11		MASTF
110					02 A11		05 A23		MASTF
111					01 B20		02 B11		SLV1F
112	↓	↓	↓		01 A21		02 A12		SLV2F
113	3	30	YEL		01 (B21		02 B12		SLV3F
114									
115									
116									
117									
118									
119									
120									

CONTROL DATA

CODE IDENT

SHEET 9

WL

DOCUMENT NO.
39895500

REV. B

CONDUCTOR IDENT.	FIND NO	GAUGE (REF.)	COLOR (REF.)	LENGTH (APPROX)	ORIGIN		ACCESS FIND NO.	DESTINATION		ACCESS FIND NO	REMARKS
121	3	30	YEL		O1	A22		O2	A13		SLV4F
122	▲	▲	▲		O1	B22		O2	B13		SLV5F
123					O1	A23		O2	A14		SLV6F
124					O1	B23		O2	B14		SLV7F
125					O2	A25		O3	B14		MCWTF
126					O3	B14		O4	B14		MCWTF
127					O2	B24		O3	A14		MCRDF
128					O3	A14		O4	A14		MCRDF
129					O5	A3		O8	A2		SSOOF
130	▼	▼	▼		O5	B3		10	A2		SSOIF
131	3	30	YEL		O5	A4		12	A2		SSOZF
132											
133											
134											
135											
136											
137											
138											
139											
140											

CONDUCTOR IDENT.	FIND NO.	GAUGE (REF.)	COLOR (REF.)	LENGTH (APPROX)	ORIGIN	ACCESS FIND NO.	DESTINATION	ACCESS FIND NO.	REMARKS
141	3	30	YEL		05		14		SS03F
142	↑	↑	↑		A5		16	↑	SS04F
143					B5		18		SS05F
144					A6		20		SS06F
145					B6		22		SS07F
146					A7		24		SS08F
147					B7		26		SS09F
148					A8		28		SS10F
149					B8		30		SS11F
150					A9		32		SS12F
151					B9		34		SS13F
152	↓	↓	↓		A10		36	↓	SS14F
153	3	30	YEL		05		38		SS15F
154	3	30	YEL		05		01		STALF
155									
156									
157									
158									
159									
160									

MF

39895500	E	CLA	A	BACKPLANE-WIRED ASSY	DS	1750-1	10/31/74	
ASSEMBLY NUMBER	REV	CLASS	DW SZ	ASSEMBLY DESCRIPTION	DESIGN SOURCE	FIRST USAGE	RELEASE DATE	CLASSIFICATION NUMBER

ASSEMBLY PARTS LIST

CONTROL DATA CORPORATION

SPARE CODE
 S = SPARE PARTS
 N = NON SPARE PARTS

FIND NUMBER	DW SZ	REV	CLASS	DW SZ	ASSEMBLY DESCRIPTION	DESIGN SOURCE	FIRST USAGE	RELEASE DATE	CLASSIFICATION NUMBER	CHANGE ORD NUMBER	DATE EFFECTIVE	CLASSIFICATION NUMBER	OP NUMBER	MAKE/BUY PART TYPE	PN NC	S OR N
7	A				10125106	PC	1800		HEXAGON MACHINE SCREW NUTS 8-32	013488	110674			PPP1	N	
8	A				10125606	PC	1800		PLAIN WASHERS *B	013488	110674			PPP1	N	
6	A				10125804	PC	1800		SPRING LOCK WASHERS (MED.) #B	013488	110674			PPP1	N	
5	A				10127124	PC	900		SCR MACH PAN PHL 8-32 X .62	013488	110674			PPP1	N	
4	A				38837921	PC	1800		SCREW NYLON 440-3/16 BINDER					AYM4	N	
1	D				39721200	PC	100		BACKPLANE (1NAT)						N	
2	H				39896300	PC	600		STIFFENER						N	
3	C				52629904	IN	100		WIRE ELECT 30 GA SOLID YELLOW					PPP3	N	

NUMBER OF LINE ITEMS = 8
 HIGHEST FIND NUMBER = 8

PROJECT ENGINEER
G. DRAKE

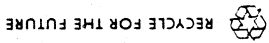

Figure 8.2. Backplane Wire List - CIE Module



REVISION RECORD				
REV	CO	DESCRIPTION	DRFT	DATE
FOR REV SEE SHEET NO. 9				

NOTES :

- I. IDENTIFY WITH PN & REV LTR BY MEANS OF TAG, LABEL OR SIMILAR METHOD.

DWN	<i>B. Johnson</i>	5-5-72	TITLE	
CHKD	<i>B. Johnson</i>	5-11-72	BACKPLANE ASSY	
ENG	<i>B. Johnson</i>	10-23-72	(COMPUTER INTERFACE EXPANDER)	
MFG	<i>C. Amuro</i>	10-30-72	CODE IDENT	DWG NO
APP			09132	A 39900000
			LA JOLLA SYSTEMS DIVISION La Jolla, Calif. 92037	
			SCALE	
			39900100 SHEET 1 OF 9	

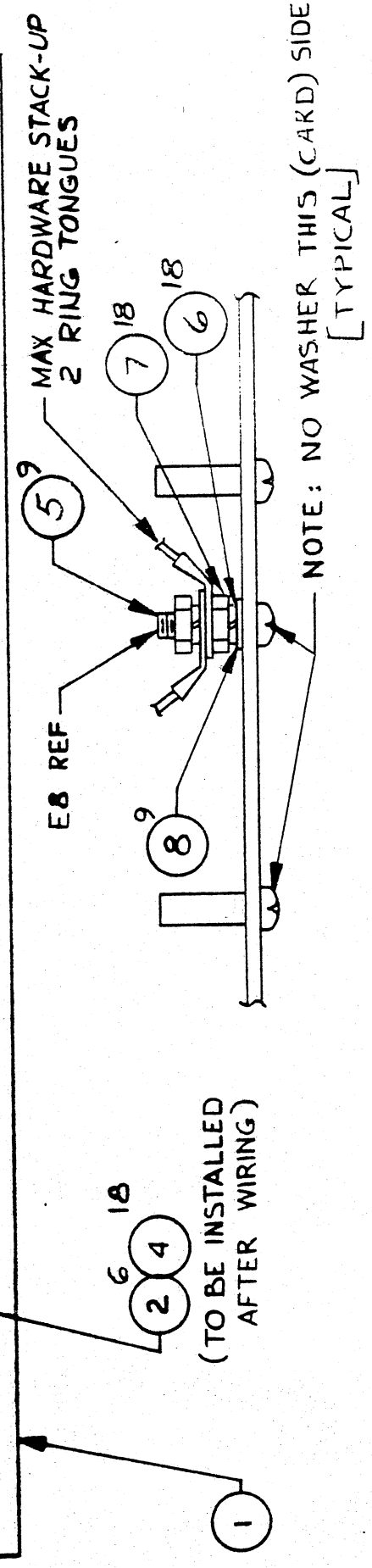
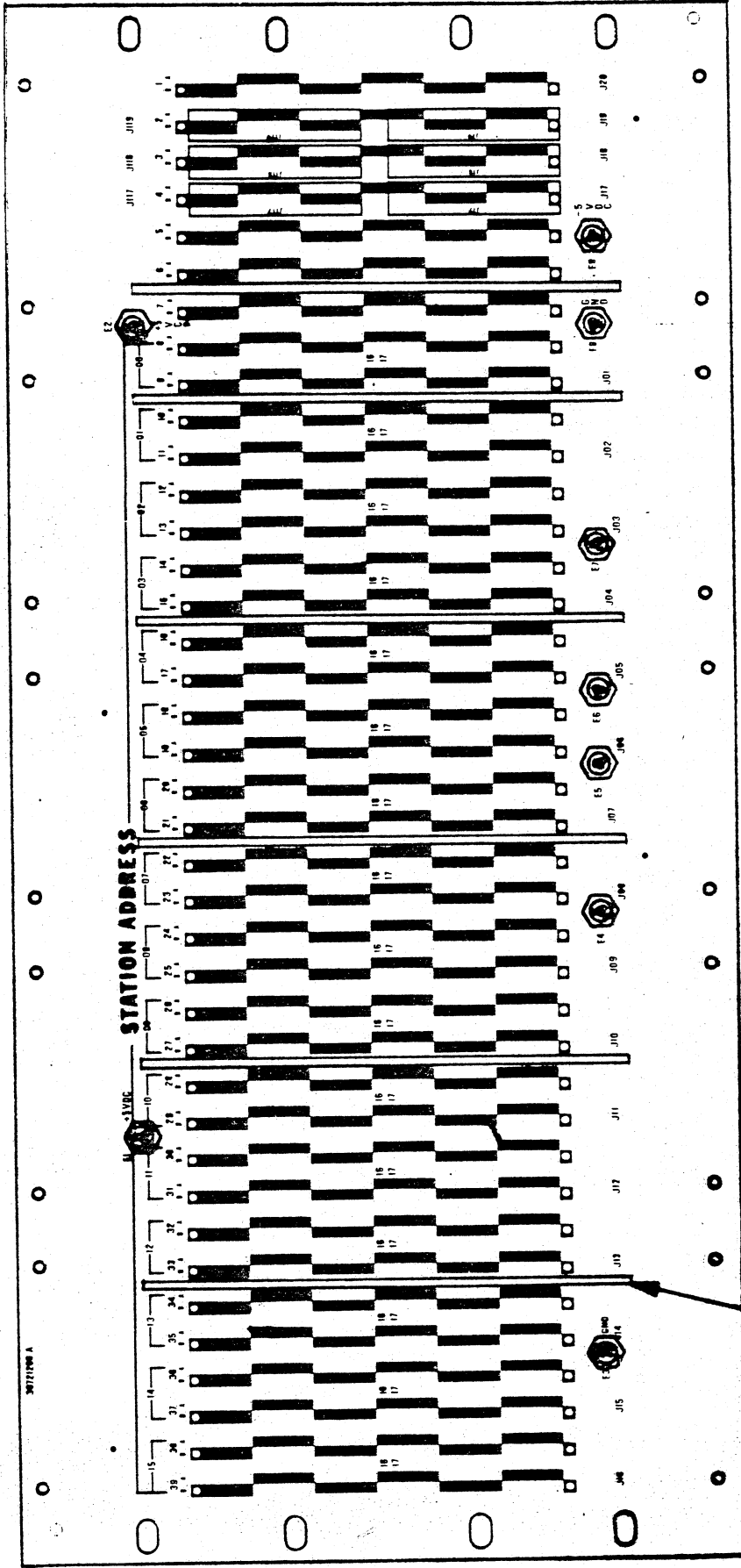

6 18
 (2) (4)
 (TO BE INSTALLED
 AFTER WIRING)

CONTROL DATA

CODE IDENT

SHEET 3

DOCUMENT NO.

3990000

REV.

A

CONDUCTOR IDENT.	FIND NO.	GAUGE (REF.)	COLOR (REF.)	LENGTH (APPROX)	ORIGIN		ACCESS FIND NO.	DESTINATION		ACCESS FIND NO.	REMARKS
1	3	30	YEL		05	A28		06	A28		CNRDF
2	↑	↑	↑		05	B28		06	B28		CNWTF
3					07	A24		10	B2		FLOIF
4					↑	B24		12	↑		FLO2F
5						A25		14			FLO3F
6						B25		16			FLO4F
7						A18		18			FLO5F
8						A19		20			FLO6F
9						B19		22			FLO7F
10						A20		24			FLO8F
11						B20		26			FLO9F
12						A21		28			FLIOF
13						B21		30			FLI1F
14						A22		32			FLI2F
15						B22		34			FLI3F
16	↑	↑	↑			A23		36	↓		FLI4F
17	3	30	YEL		07	B23		38	B2		FLI5F
18											
19											
20											

CONTROL DATA

DOCUMENT NO.
39900000

REV.
A

SHEET
4

CODE IDENT

WL

CONDUCTOR IDENT.	FIND NO.	GAUGE (REF.)	COLOR (REF.)	LENGTH (APPROX)	ORIGIN		ACCESS FIND NO.	DESTINATION		ACCESS FIND NO.	REMARKS
					ORIGIN	ORIGIN		DESTINATION	DESTINATION		
21	3	30	YEL		O1	A26		O7	A26		INT1F
22	↑	↑	↑		↑	B26		↑	B26		INT2F
23						A27			A27		INT3F
24						B27			B27		INT4F
25						A28			A28		INT5F
26						B28			B28		INT6F
27						A29		↓	A29		INT7F
28						B29		O7	B29		INT8F
29						A14		O5	A14		ISY1F
30						B14		↑	B14		ISY2F
31						A11			A27		MRDF
32						B11			B27		MWTF
33						A12			A22		MFS TF
34						A13			B29		MRJTF
35	↑	↑	↑			B12		↓	A29		MRPYF
36	3	30	YEL		O1	B13		O5	B22		MMCLF
37											
38											
39											
40											

CONTROL DATA

CODE IDENT

SHEET

5

WL

DOCUMENT NO.

39900000

REV.

A

CONDUCTOR IDENT	FIND NO	GAUGE (REF)	COLOR (REF)	LENGTH (APPROX)	ORIGIN	ACCESS FIND NO.	DESTINATION	ACCESS FIND NO.	REMARKS
41	3	30	YEL		O1		O5		MC1NF
42					A3		O6		MAOOF
43					B3				MAOIF
44					A4				MAO2F
45					B4				MAO3F
46					A5				MAO4F
47					B5				MAO5F
48					A6				MAO6F
49					B6				MAO7F
50					A7				MAO8F
51					B7				MAO9F
52					A8				MAIOF
53					B8				MAI1F
54					A9				MAI2F
55					B9				MAI3F
56					A10				MAI4F
57	3	30	YEL		O1		O6		MAI5F
58									
59									
60									

CONTROL DATA

CODE IDENT

SHEET

6

WL

DOCUMENT NO.

39900000

REV

B

CONDUCTOR IDENT	FIND NO	GAUGE (REF)	COLOR (REF)	LENGTH (APPROX)	ORIGIN		ACCESS FIND NO	DESTINATION		ACCESS FIND NO	REMARKS
61	3	30	YEL		01	A16		05	A20		MQQQF
62	↑	↑	↑		↑	B16		↑	B20		MQO1F
63						A17			A21		MQO2F
64						B17			B21		MQO3F
65						B20			B23		SLV1F
66						A21			A24		SLV2F
67						B21			B24		SLV3F
68						A22			A25		SLV4F
69						B22			B25		SLV5F
70					↓	A23		↓	A26		SLV6F
71					01	B23		05	B26		SLV7F
72					05	A3		08	A2		SSOOF
73					↑	B3		10	↑		SSO1F
74	↓	↓	↓		↓	A4		12	↓		SSO2F
75	3	30	YEL		05	B4		14	A2		SSO3F
76											
77											
78											
79											
80											

CONTROL DATA

CONTROL DATA				CODE IDENT		SHEET 7		WL		DOCUMENT NO. 39900000		REV C	
CONDUCTOR IDENT.	FIND NO	GAUGE (REF.)	COLOR (REF.)	LENGTH (APPROX)	ORIGIN		ACCESS FIND NO.	DESTINATION		ACCESS FIND NO.	REMARKS		
81	3	30	YEL		O5	A5		16	A2		SSO4F		
82	↑	↑	↑		↑	B5		18	↑		SSO5F		
83						A6		20			SSO6F		
84						B6		22			SSO7F		
85						A7		24			SSO8F		
86						B7		26			SSO9F		
87						A8		28			SS10F		
88						B8		30			SS11F		
89						A9		32			SS12F		
90						B9		34			SS13F		
91	↓	↓	↓		↓	A10		36	↓		SS14F		
92	3	30	YEL		O5	B10		38	A2		SS15F		
93	3	30	YEL		O5	B15		01	B15		STALF		
94													
95													
96													
97													
98													
99													
100													

01/02/75 1/1
 PROCESSING DATE
 PAGE NUMBER

MF

39900000	D	CLA	A	BACKPLANE ASSY-CMPTR INTF EXP	DS	1500	11/08/74	CLASSIFICATION NUMBER
ASSEMBLY NUMBER	REV	CLASS	SZ	ASSEMBLY DESCRIPTION	DESIGN SOURCE	FIRST USAGE	RELEASE DATE	CLASSIFICATION NUMBER

ASSEMBLY PARTS LIST

CONTROL DATA CORPORATION

SPARE CODE
 S = SPARE PARTS
 N = NON SPARE PARTS

FIND NUMBER	DW SZ	REV	CLASS	SZ	PART NUMBER	QUANTITY	UNIT MEAS.	PART DESCRIPTION	IN/OUT STATUS	CHANGE ORD NUMBER	DATE EFFECTIVE	CLASSIFICATION NUMBER	OP NUMBER	MAKE/BUY PART TYPE	PN OR NC
7	A				10125106	1800	PC	HEXAGON MACHINE SCREW NUTS 8-32	IN	013488	110874			PPPI	N
8	A				10125606	1800	PC	PLAIN WASHERS #8	IN	013488	110874			PPPI	N
6	A				10125804	1800	PC	SPRING LOCK WASHERS (MED.) #8	IN	013488	110874			PPPI	N
5	A				10127124	900	PC	SCR MACH PAN PHL 8-32 X .62	IN	013488	110874			PPPI	N
4	A				38R37921	1800	PC	SCREW, NYLON, 440-3/16 BINDER	IN					AYM4	N
1	D				39721200	100	PC	BACKPLANE (INAT)	IN						N
2	R				39896300	600	PC	STIFFENER	IN						N
3	C				52629904	100	IN	WIRE ELECT 30 GA SOLID YELLOW	IN					PPP3	N
NUMBER OF LINE ITEMS = 8 HIGHEST FIND NUMBER = 8															

PROJECT ENGINEER
G DRAKE

DWN		CONTROL DATA <small>ANALOG - DIGITAL SYSTEMS DIVISION La Jolla, Calif 92037</small> CODE IDENT 09132	TITLE BACKPLANE ASSY (COMPUTER INTERFACE EXPANDER) FIRST USED ON	PREFIX DOCUMENT NO. 39900000	REV D
CHKD					
ENG					
MFG					
APPR					

SHEET REVISION STATUS		REVISION RECORD				
REV	ECO	DESCRIPTION	DRFT	DATE	APP	
01			<i>B</i>	5-23-72	<i>E. J.</i>	
A	DDC	CHG SIGNALS, COND 72-92 ECR 4170	<i>B9</i>	10-30-72	<i>E. J.</i>	
B	13169	CHG SIGNALS COND 72-75, 81-92, ADDED 93	<i>AK</i>	6-19-73	<i>E. J.</i>	
C	13379	CHG COND IDENT 93	<i>BR</i>	11-7-74	<i>E. J.</i>	
D	13488	ADDED FN 5-8 TO SH2 & PL	<i>RJR</i>	2-17-75	<i>E. J.</i>	

NOTES:

DETACHED LISTS



Figure 8.3. Chassis Wire List - CIU Module



DWN	<i>Bob Johnson</i>	5-7-72	CONTROL DATA	TITLE	CHASSIS - COMPUTER INTERFACE UNIT	PREFIX	WL	DOCUMENT NO.	39874500	REV	A
CHKD	<i>Bob Johnson</i>	5-11-72	ANALOG - DIGITAL SYSTEMS DIVISION La Jolla, Calif. 92037	FIRST USED ON	EL 101A						
ENG			CODE IDENT								
MFG			09132								
APPR											

SHEET REVISION STATUS				REVISION RECORD			
REV	ECO	DESCRIPTION	DRET	DATE	APP		
01		ADDED: NOTE 3 & SIGNALS. COND IDENT 22 WAS J19-A19. - ECR 4696 - 4#	<i>BJ</i>	5-23-72	<i>W.P.E.</i>		
02	DDC		<i>BJ</i>	7-24-72	<i>E. L.</i>		
A	DDC	ECR4771	<i>BJ</i>				

NOTES:

- LABEL'S (FN 12 & 14) TO BE IDENTIFIED WITH APPROPRIATE "J" NO. AND LOCATED APPROX AS SHOWN.
- INSERT CONTACT (FN 11) IN J20 AT PIN A18, B19, A19 & B30.
- INSTALL CONTACT FN 11 @ J17 & J18.

DETACHED LISTS

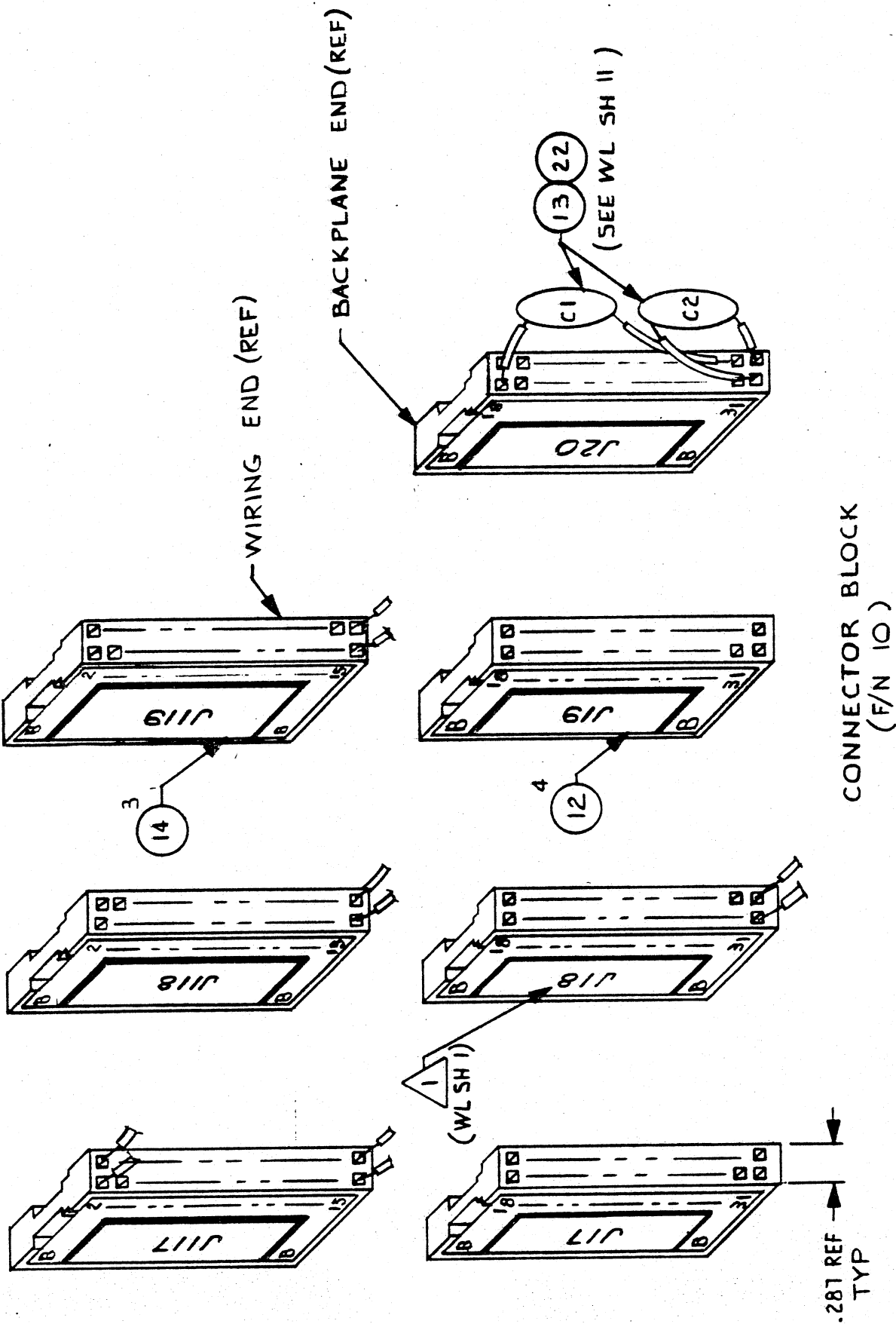

CONTROL DATA CORPORATION
LA JOLLA SYSTEMS DIVISION
 La Jolla, Calif. 92037

CODE IDENT **09132** SHEET **3** WL DOCUMENT NO. **39874500** REV **A**

CONDUCTOR IDENT	FIND NO	GAUGE (REF.)	COLOR (REF.)	LENGTH (APPROX)	ORIGIN	ACCESS FIND NO.	DESTINATION	ACCESS FIND NO.	DESTINATION
1	18	28/26	WHT		J23		J24		J119
2			BLK						
3									
4									
5									
6									
7									
8									
9									
10									
11									
12									
13									
14									
15									
16									
17	18	28/26	WHT						
18			BLK		J23		J24		J119
19									
20									

CONTROL DATA

LA JOLLA SYSTEMS DIVISION
La Jolla, Calif. 92037

CODE IDENT
09132

SHEET **4**

WL

DOCUMENT NO.
39874500

REV.
A

CONDUCTOR IDENT	FIND NO	GAUGE (REF.)	COLOR (REF.)	LENGTH (APPROX)	ORIGIN	ACCESS FIND NO.	DESTINATION	ACCESS FIND NO.	DESTINATION	ACCESS FIND NO.	
21	18	28/26	WHT		J23	B9	J24	B9	J19	A18	\$Q09
22			BLK			B10		B10		B19	
23	18	28/26	WHT			C1		C1		A20	\$Q10
24			BLK			C2		C2	J19	B20	
25	19	28	WHT			C3		C3			
26			BLK			C4		C4			
27						C5		C5			
28						C6		C6			
29						C7		C7			
30						C8		C8			
31						C9		C9			
32						C10		C10			
33	19	28	WHT			D1		D1			
34			BLK			D2		D2			
35	18	28/26	WHT			D3		D3	J19	A21	\$READ
36			BLK			D4		D4		B21	
37	18	28/26	WHT			D5		D5		A23	\$WRITE
38			BLK		J23	D6	J24	D6	J19	B23	
39											
40											

PRINTED IN U.S.A.

CONTROL DATA
CORPORATION

LA JOLLA SYSTEMS DIVISION
La Jolla, Calif. 92037

CODE IDENT
09132

SHEET **5**

WL

DOCUMENT NO.

39874500

REV.

A

CONDUCTOR IDENT	FIND NO	GAUGE (REF.)	COLOR (REF.)	LENGTH (APPROX)	ORIGIN	ACCESS FIND NO.	DESTINATION	ACCESS FIND NO.	DESTINATION	ACCESS FIND NO.
41	18	28/26	WHT		J23	D7	J24	D7	J19	A26 } \$MCLF
42			BLK			D8		D8		B26 }
43	18	28/26	WHT			D9		D9		A27 } \$PPRO
44			BLK			D10		D10	J19	B27 }
45	19	28	WHT			E1		E1		
46			BLK			E2		E2		
47						E3		E3		
48						E4		E4		
49						E5		E5		
50						E6		E6		
51						E7		E7		
52						E8		E8		
53						E9		E9		
54						E10		E10		
55						F1		F1		
56						F2		F2		
57	19	28	WHT			F3		F3		
58			BLK		J23	F4	J24	F4		
59										
60										

CONTROL DATA

LA JOLLA SYSTEMS DIVISION
La Jolla, Calif. 92037

CODE IDENT
09132

SHEET **6**

WL

DOCUMENT NO.
39874500

REV.
A

CONDUCTOR IDENT	FIND NO	GAUGE (REF.)	COLOR (REF.)	LENGTH (APPROX)	ORIGIN	ACCESS FIND NO	DESTINATION		ACCESS FIND NO	DESTINATION	ACCESS FIND NO
61	19	28	WHT		J23		J24	F5			
62			BLK		/		/	F6			
63	18	28/26	WHT					F7	J19	A28	\$WEGO
64			BLK					F8	/	B28	
65	18	28/26	WHT					F9		A30	+20V
66			BLK		/		/	F10	/	A31	-20V
67	21	28/26	BLK		J23		J24	C	J19	B31	GND
68	18	28/26	WHT		J21		J22	A1	J118	A2	\$A00
69			BLK		/		/	A2	/	B2	
70								A3		A4	\$A01
71								A4		B4	
72								A5		A5	\$A02
73								A6		B5	
74								A7		A7	\$A03
75								A8		B7	
76	18	28/26	WHT		/		/	A9	/	A8	\$A04
77			BLK		J21		J22	A10	J118	B8	
78											
79											
80											

PRINTED IN U.S.A.

CONTROL DATA
CORPORATION

LA JOLLA SYSTEMS DIVISION
La Jolla, Calif. 92037

CODE IDENT
09132

SHEET **7**

WL

DOCUMENT NO.

39874500

REV.

A

CONDUCTOR IDENT	FIND NO	GAUGE (REF.)	COLOR (REF.)	LENGTH (APPROX)	ORIGIN	DESTINATION		ACCESS FIND NO	DESTINATION	ACCESS FIND NO	
						JZZ	B1				
81	18	28/26	WHT		JZ1	B1	JZZ		J118	A10	\$A05
82			BLK			B2	/			B10	
83						B3				A11	\$A06
84						B4				B11	
85						B5				A13	\$A07
86						B6			J118	B13	
87						B7			J117	AZ	\$A08
88						B8			/	BZ	
89						B9				A4	\$A09
90						B10				B4	
91						C1				A5	\$A10
92						C2				B5	
93						C3				A7	\$A11
94						C4				B7	
95						C5				AB	\$A12
96						C6				B8	
97	18	28/26	WHT			C7	/			A10	\$A13
98			BLK		JZ1	C8	JZZ		J117	B10	
99											
100											

CONTROL DATA
CORPORATION

LA JOLLA SYSTEMS DIVISION
La Jolla, Calif. 92037

CODE IDENT
09132

SHEET **8**

WL

DOCUMENT NO.
39874500

REV.
A

CONDUCTOR IDENT.	FIND NO	GAUGE (REF.)	COLOR (REF.)	LENGTH (APPROX)	ORIGIN	ACCESS FIND NO.	DESTINATION	ACCESS FIND NO.	DESTINATION	ACCESS FIND NO.
101	18	28/26	WHT		J21		J22		J117	
102	1	1	BLK		1		1		1	
103										
104										
105										
106										
107										
108	1	1	WHT							
109	18	28/26	WHT							
110			BLK							
111	19	28	WHT							
112	1	1	BLK							
113										
114										
115										
116	1	1	WHT							
117	19	28	WHT							
118			BLK		J21		J22			
119										
120										

CONTROL DATA LA JOLLA SYSTEMS DIVISION
 La Jolla, Calif. 92037

CCREORA C. CODE IDENT **09132** SHEET **9** WL **39874500** REV. **A**

CONDUCTOR IDENT	FIND NO	GAUGE (REF.)	COLOR (REF.)	LENGTH (APPROX)	ORIGIN		ACCESS FIND NO.	DESTINATION		ACCESS FIND NO.	DESTINATION	ACCESS FIND NO.	DESTINATION
					J21	E7		J22	E7				
121	19	28	WHT		J21	E7		J22	E7				
122	1	1	BLK			E8			E8				
123						E9			E9				
124						E10			E10				
125						F1			F1				
126						F2			F2				
127						F3			F3				
128						F4			F4				
129						F5			F5				
130	1	1				F6			F6				
131	19	28	WHT			F7			F7				
132			BLK			F8			F8				
133	18	28/26	WHT			F9			F9		J18	A30	+20V
134			BLK			F10			F10		J18	A31	-20V
135	21	28/26	BLK		J21	C		J22	C		J18	B31	GND
136													
137													
138													
139													
140													

CONTROL DATA
LA JOLLA SYSTEMS DIVISION
La Jolla, Calif. 92037

CORPORATION

CODE IDENT
09132

SHEET **10**

WL

DOCUMENT NO.
39874500

REV.
A

CONDUCTOR IDENT	FIND NO	GAUGE (REF.)	COLOR (REF.)	LENGTH (APPROX)	ORIGIN	ACCESS FIND NO.	DESTINATION	ACCESS FIND NO.	DESTINATION	ACCESS FIND NO.
141	2	26	BLK		J25		J26		J27	
142	1	1	1		J27		J28		J17	
143	1	1	1		J29		J30		J31	
144	2	26	BLK		J31		J32		J18	
145	20	26	WHT		J25	A	J17	AZ0		\$INT1
146	1	1	BLK		J25	B	1	BZ0		
147			1		J26	A		AZ2		\$INT2
148					J26	B		BZ2		
149					J27	A		AZ3		\$INT3
150					J27	B		BZ3		
151					J28	A	1	AZ5		\$INT4
152					J28	B	J17	BZ5		
153					J29	A	J18	AZ0		\$INT5
154					J29	B	1	BZ0		
155					J30	A		AZ2		\$INT6
156	1	1	1		J30	B		BZ2		
157	20	26	WHT		J31	A	1	AZ3		\$INT7
158			BLK		J31	B	J18	BZ3		
159										
160										

3
3

PRINTED IN U.S.A.

CONTROL DATA
CORPORATION

LA JOLLA SYSTEMS DIVISION
La Jolla, Calif. 92037

CODE IDENT
09132

SHEET **11**

WL

DOCUMENT NO.
39874500

REV.
A

CONDUCTOR IDENT	FIND NO	GAUGE (REF)	COLOR (REF)	LENGTH (APPROX)	ORIGIN	ACCESS FIND NO	DESTINATION	ACCESS FIND NO	DESTINATION	ACCESS FIND NO
161	20	26	WHT		J32	A	J18	A25	J17	11
162			BLK		J32	B	J18	B25		11
163	20	26	WHT		J33	A	J34	A	J17	
164			BLK		J33	B	J34	B	J17	
165	13				C2	-	J20	A31		11
166					C2	+	J20	B31		11
167	13				C1	-	J20	B18		11
168					C1	+	J20	A30		11
169										
170										
171										
172										
173										
174										
175										
176										
177										
178										
179										
180										

\$INT8

3

3

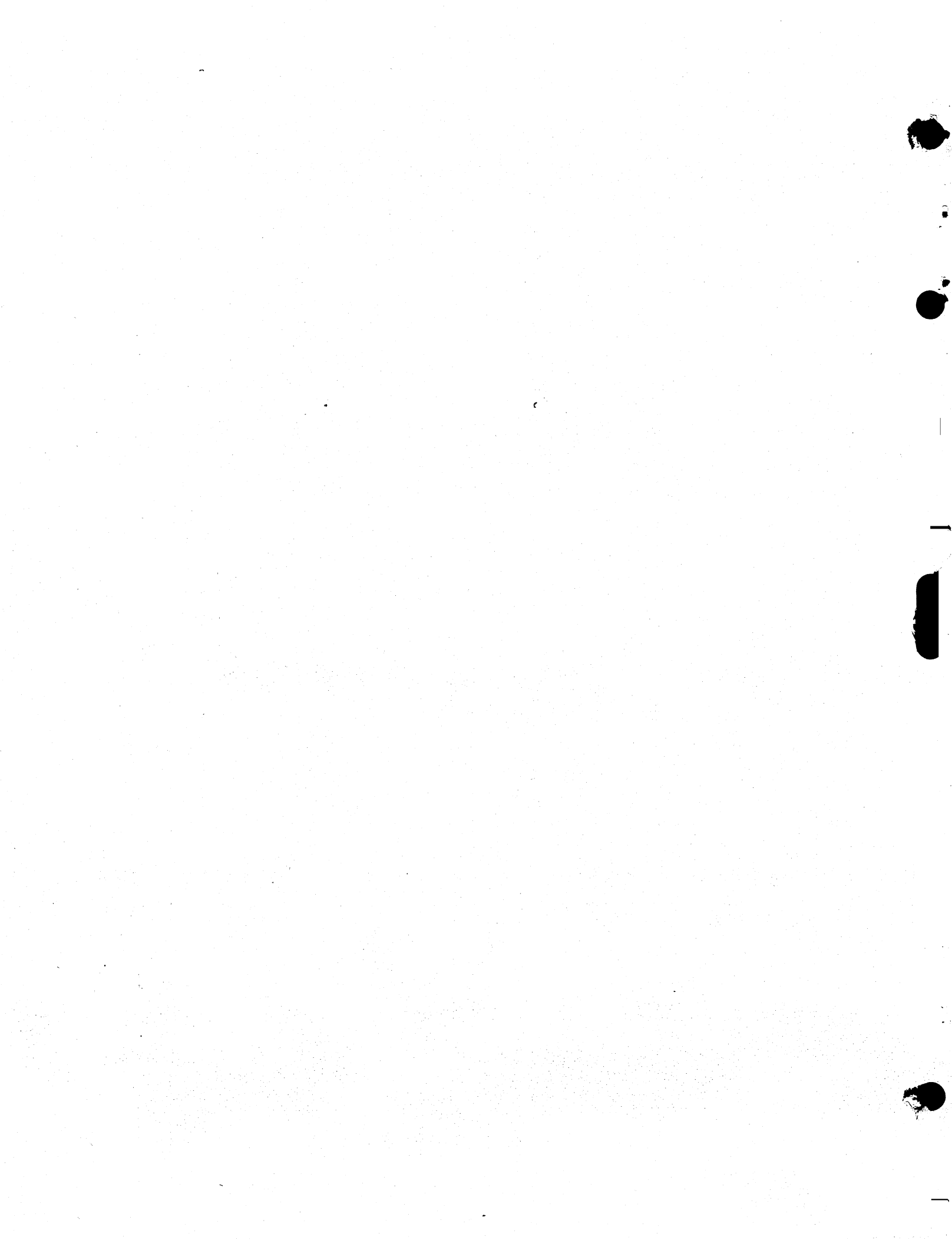

COMMENT SHEET

MANUAL TITLE EL101-A Computer Interface Unit/EL102-A Computer Interface
Expander Hardware Reference/Maintenance Manual

PUBLICATION NO. 88980100 REVISION E

FROM NAME: _____

BUSINESS
ADDRESS: _____

COMMENTS: This form is not intended to be used as an order blank. Your evaluation of this manual will be welcomed by Control Data Corporation. Any errors, suggested additions or deletions, or general comments may be made below. Please include page number.

CUT ALONG LINE

STAPLE

STAPLE

FOLD

FOLD



NO POSTAGE
NECESSARY
IF MAILED
IN THE
UNITED STATES

BUSINESS REPLY MAIL
FIRST CLASS PERMIT NO. 8241 MINNEAPOLIS, MINN.

POSTAGE WILL BE PAID BY

CONTROL DATA CORPORATION
PUBLICATIONS AND GRAPHICS DIVISION
4455 EASTGATE MALL
LA JOLLA, CALIFORNIA 92037

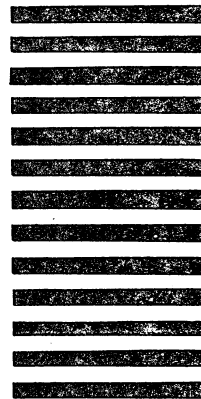

CUT ALONG LINE

FOLD

FOLD